

# Hamilton Horizon Fume Hoods



## Operation, Maintenance and Installation Instructions



Introduction ..... 2

Fume Hood Component Identification ..... 3-4

Installation ..... 5-9

    Fume Hood Installation ..... 5-8

    Fume Hood Monitor ..... 9

    Minihelic Gauge Installation ..... 9

Warning and Operating Instructions ..... 10

Maintenance and Adjustments ..... 11

    General Maintenance of Fume Hoods ..... 11

    Fume Hood Inspection Procedures ..... 11

    Fluorescent Light Tube Replacement ..... 11

    Fume Hood Valves ..... 11

    Fume Hood Interiors ..... 11

    Side Frame Glass Replacement ..... 12

    Cable Replacement ..... 12

    Sash Glass Replacement ..... 13

    Blower Adjustments ..... 13

Fume Hood Testing ..... 14-16

Troubleshooting ..... 17

Dimensions are nominal, and illustrations and specifications are based on the latest product information available at the time of publication. The right is reserved to make changes at any time without notice.

This product NOT evaluated for use with Perchloric Acid or Radioisotopes by UL

Fume hoods are exposed to temperature extremes, reagent fumes and work surface abuse. Regular care will prolong service life and ensure safe working conditions.

The exhaust system and blower of a fume hood must function properly for safety. Maintenance personnel should service the fan and motor assembly regularly, lubricate as required, and ensure that the exhaust system is free from obstructions. Semi-annually, accumulated deposits should be removed from the impeller blade and housing.

A simple test with smoke will show if the air is being drawn into the hood. More accurate checks of air velocity can be made with a thermal anemometer. See inspection and field evaluation procedure.

Always place equipment or apparatus as far back into the fume hood as possible since this provides greater assurance of proper fume collection and removal.

Large bulky apparatus or equipment should be placed in the fume hood to permit air flow around it. Raise large items an inch or two above work surface. Spilled liquids, acids, or corrosive materials should be immediately wiped up and the surface neutralized with water, or the proper neutralizing agent, to prevent damage to the work surface, hood interior, apparatus and installed equipment.

Single-sided Fume Hood

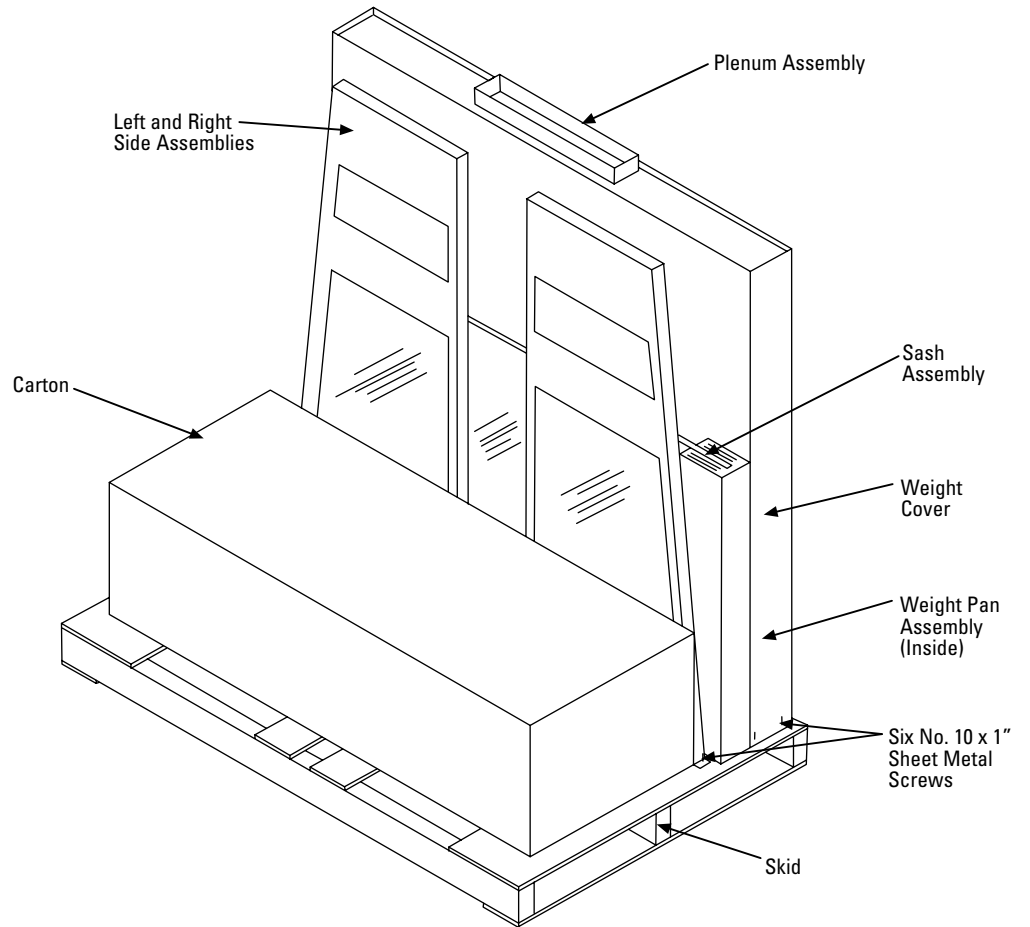

**Carton contents not shown:**

- Sill Assembly
- Front Panel Assembly
- Top Front Panel Assembly
- LH Pipe Chase Assembly
- RH Pipe Chase Assembly
- RH Upright Bracket Assembly
- RH Cornerpost Assembly
- LH Cornerpost Assembly
- Top Panel Assembly
- Hardware Bag

**Sash and counterweight are matched sets.**

Label is located on the inside of sill cover.

Product Number	----- FH3620260102	Item: 46
Description	----- X54L852RB	— SKETCH, HD03

Example

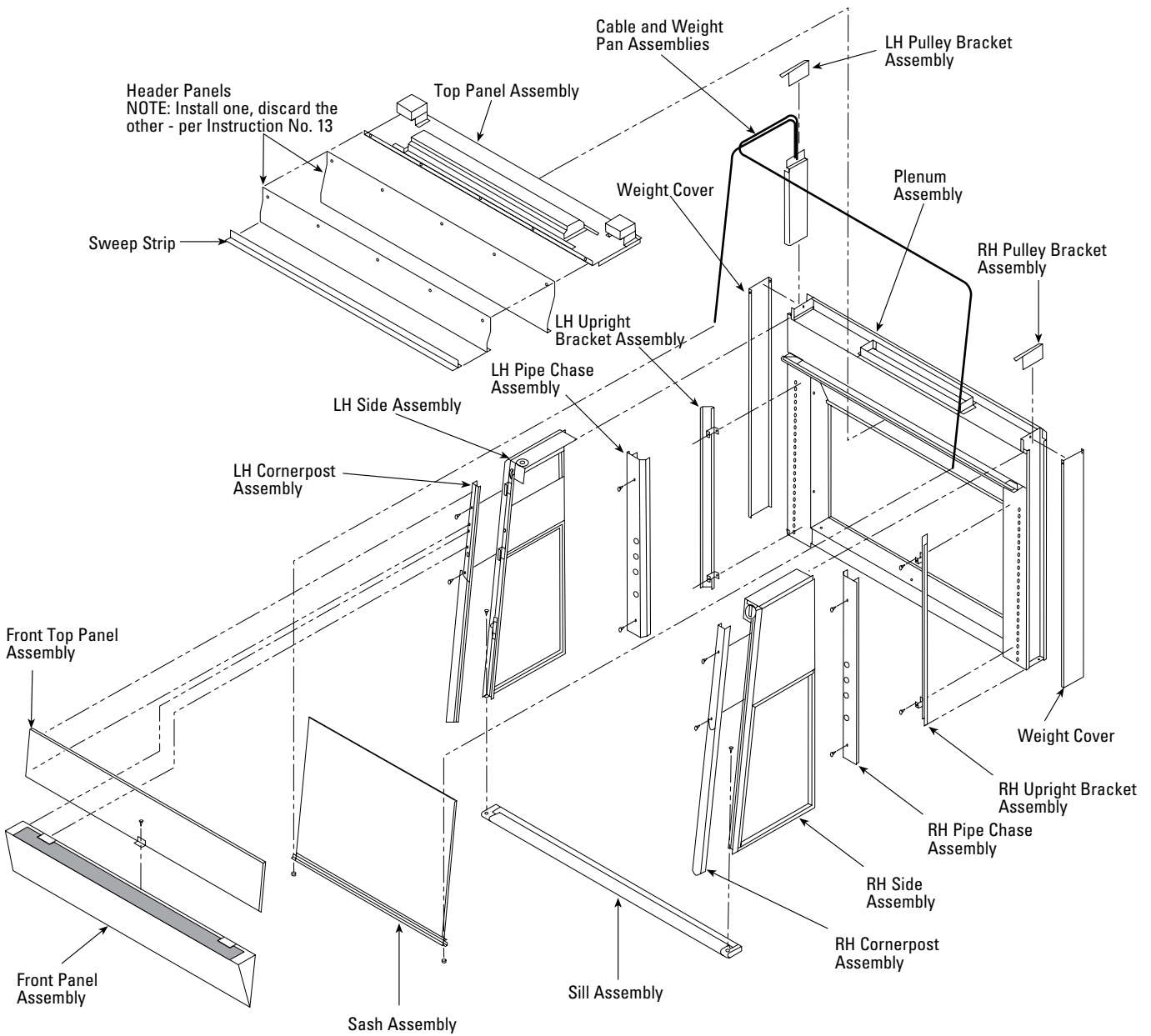

### Fume Hood Installation

**When building a multiple unit assembly, hoods must be assembled from right to left.**

1. Remove unit from skid and discard all packaging. Be carefully handle glass panels. Do not discard hardware bag supplied.
2. Locate base units in desired location. Make sure units are level.

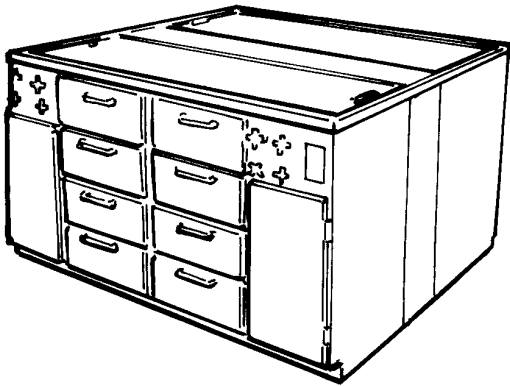

3. Install work surface(s) to top of base units.
4. Remove weight side panels. Center plenum(s) work surface. (On double hoods, align "V" notches where work surfaces join). Fasten plenum to work surface with two screws at each end.

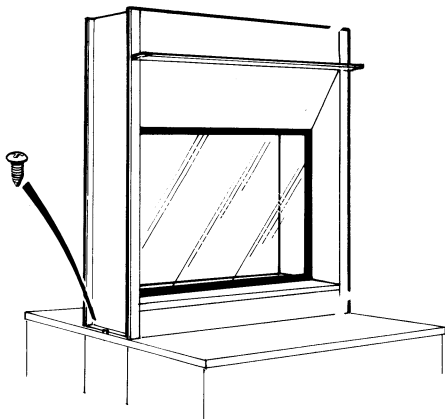

5. Remove pulley bracket assembly from both ends. Raise weight pan/cable assembly to top of hood and lock in installation position.

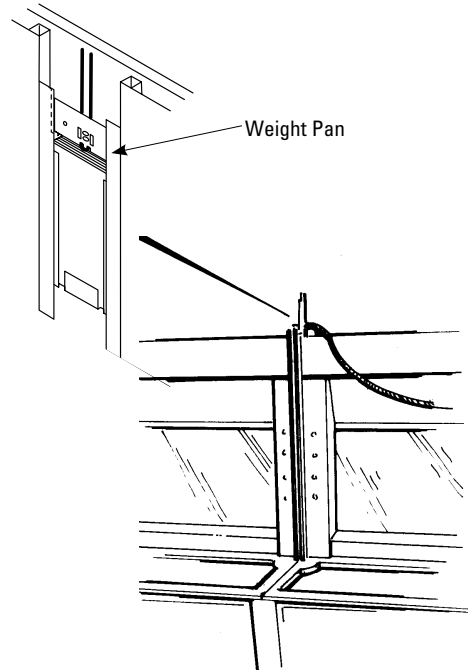

6. Remove from carton and install both right and left upright bracket assemblies.

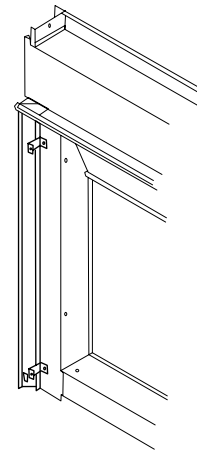

7. Run conduit from inside base cabinet, through hole in work surface, then through hole in top of plenum. Tape conduit in place raceway.

8. Remove both right and left pipe chase assemblies from the carton and install supply side valve tubing through either the hole in work surface or hole in top plenum (per plumbing specifications). Make sure adequate tubing protrudes through hole in work surface, for connection to valve controls. If vacuum breaker is required, insert cold water tubing through hole in top of plenum. When a hood is ordered pre-piped, a connection must still be made between the valve in base unit and tubing from superstructure.

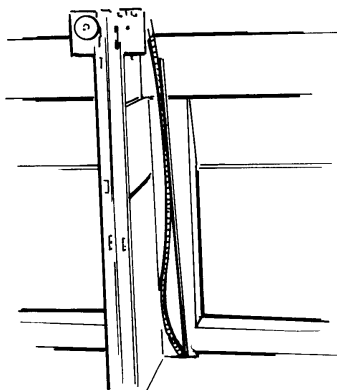

11. Install pipe chase assembly to hood. Fasten using supplied screws and plastic caps.

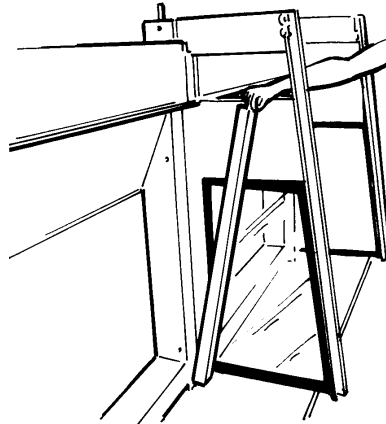

9. Install side panels. Top of panel should fit into outer slot. Bottom of panel slides over plenum tab. All panels must rest flush on work surface.

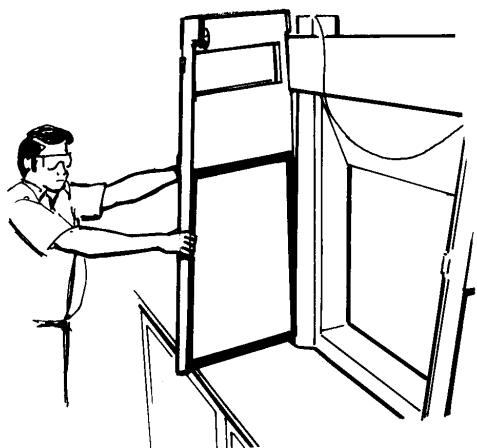

12. Remove from carton and install front sill. Make sure sill engages screw and washer located underneath each side panel end, then fasten each sill end to a side panel using one screw on top of sill through hole in tab of side panel.

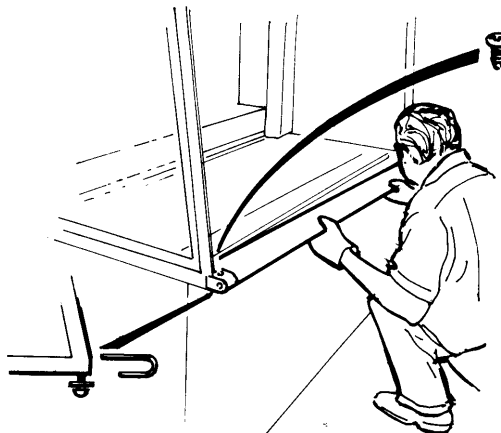

10. Install pulley brackets on plenum and side panels. **Install lattice rack, if applicable.**

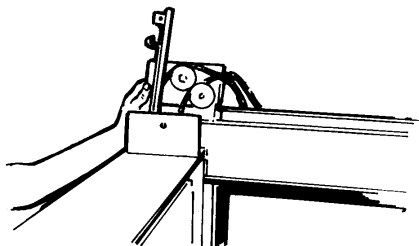

13. Install top panel and light assembly to top of hood. Slide top panel into extrusion at rear of hood. Make sure top panel is in extrusion, if not, gently pound into place with a rubber mallet.

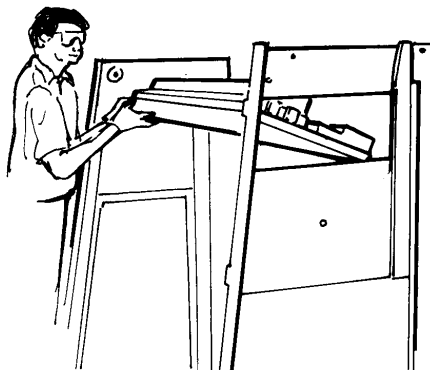



**Determine hood exhaust system requirement**

Attach appropriate panel to hood top with supplied screws (No. 8 x 3/4").

4-1/2" high panel for constant volume  
or  
9-1/2" high panel for variable air volume

Attach sweep strip as shown.

Discard unneeded header panel.

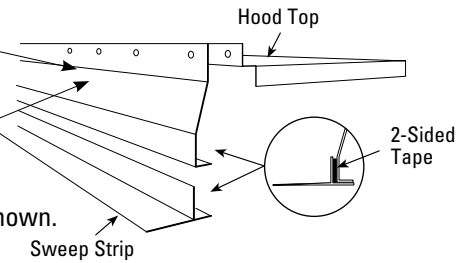

16. Remove both right and left corner posts from carton. Engage tab at bottom of corner post and fasten with two screws at top. Remove blocks of wood from under sash.



14. Thread cable through pulleys. Make sure cable ends are equidistant on both sides of sash. Install sash to side panel. Support sash with two equal blocks of wood. Install threaded end of cable to each side of sash with a nut. Threads should protrude 1/4" after installing nut.

17. Tighten all cable keepers maintaining a 1/16" gap between keeper and pulley sheave.

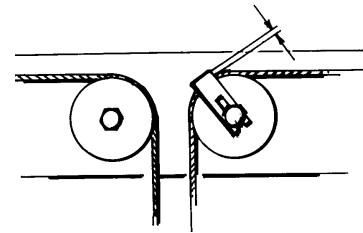
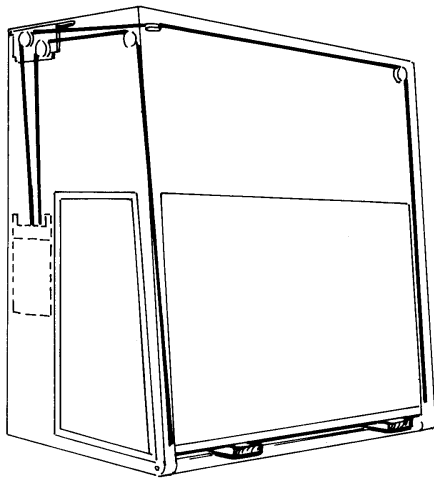

15. Remove counterweight shipping tape. Engage angle on counterweight with angle of sash pull.

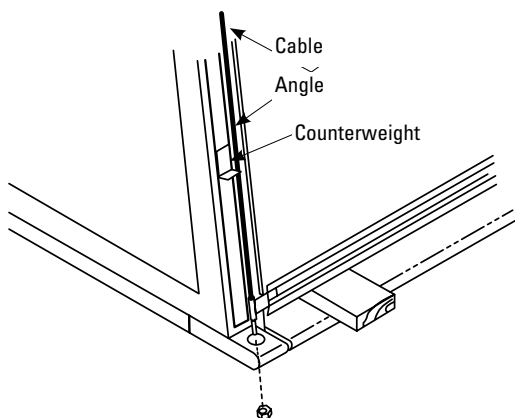

18. Lift sash all the way up, then let it close under it's own weight. With counterweight in place, and cables properly adjusted, sash should close to an 18" opening. Under 18", the sash should remain in a stationary position.

**Remove or add small weight plates to achieve proper closure.**

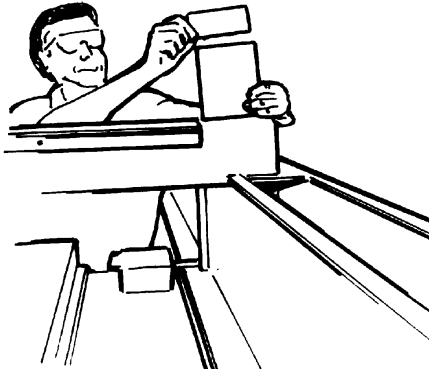

20. Remove from carton and install top panel(s) in slots provided for tabs. For safety purposes, fasten center angle with screw.

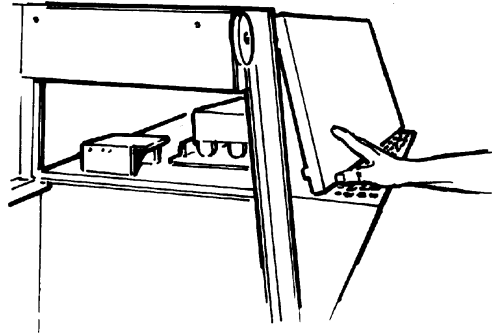

19. Remove from carton and install front panel(s) in the slots provided for the tabs.

**If front panel has a vacuum breaker mounted on top, remove appropriate side panel by disengaging top, inside screw. Separate from hook and loop fasteners. Run copper tubing through slot in corner post and to top of hood. Replace panel.**

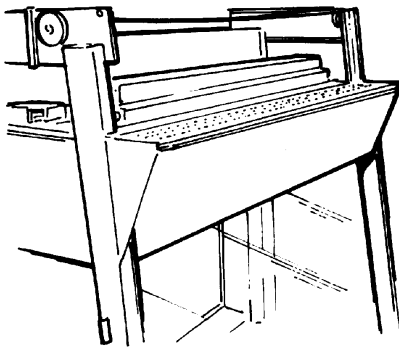

21. Replace weight side panels. Check hood - it should be square and plumb.

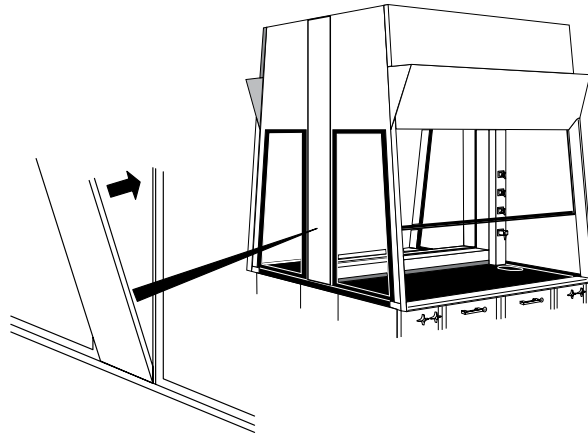

22. Install ducts to top of hood(s).  
 23. When hood is installed, complete all information on operating instruction label.

**Fume Hood Monitor**

Proper fume hood operation is key to laboratory safety, comfort and energy management. OSHA requires that laboratories take measures to ensure proper and adequate operation of fume hoods. Recommendations include the use of a continuous air monitoring device. The ANSI Z9.5 and NFPA 45 standards reinforce these requirements.

Operation manuals are provided with Hamilton fume hood monitors at shipment.

**Minihelic Guage Installation**

Replacement filter sets consist of one rough and one HEPA filter:

Product Number 54L30200 - Filter set for 54L29600 or 54L29800.

Product Number 54L30000 - Filter set for 54L29700 or 54L29900.

Complete installation instructions are included with the Minihelic Gauge.

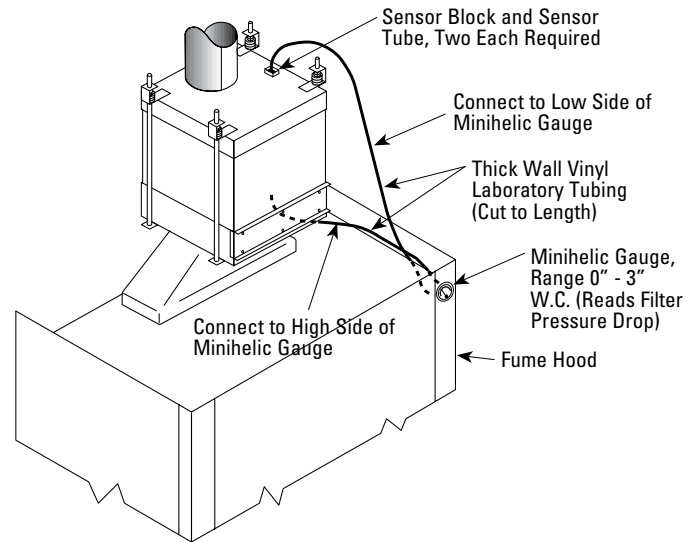

## Warning

This product is intended for use with certain chemicals that can cause serious injury or illness through inhalation or physical contact. While this product is intended to minimize exposure to certain hazardous chemicals when selected, installed and operated properly, its performance and the safety of the user is affected by a number of factors. These include the HVAC system, specific chemicals and processes being used, proper operation and condition of the room.

Before using this fume hood, consult the owner's industrial hygienist or safety representative to make sure: 1) the specific fume hood alarms, controls and the HVAC system have been properly selected and are operating correctly, 2) the hood has been tested after installation and routinely thereafter to ensure the fume hood is providing the proper containment for specific chemicals and processes being used, 3) there has been appropriate training on the correct use of the fume hood and handling of the specific chemicals and the fume hood operating instructions have been reviewed, 4) any personal protective devices that are required are properly selected and provided, and 5) the fume hood is being operated at the appropriate face velocity. The fume hood should never be operated with the sash in the full open position.



## Operating Instructions

**Failure to follow these instructions could result in physical injury or illness.**

**Caution: Do not use hood for perchloric acid procedures.**

1. Do not use this fume hood unless you have received proper training from the owner's industrial hygienist or safety representative.

2. This fume hood is not intended to be used with all chemicals or all chemical processes. Consult the owner's industrial hygienist or safety representative to determine whether the hood is appropriate for the chemicals and processes to be used.
3. Verify that the fume hood exhaust system and controls are operating properly and providing necessary air flow. If in doubt, the owner's industrial hygienist or safety representative should be consulted. It is recommended that the hood be equipped with an air flow monitoring device. Before using the fume hood, verify the monitor is operating properly by testing the monitor.
4. The hood should not be operated with the sash in the full open (set-up) position. When the hood is in use, opening of the sash glass should be kept at a minimum. On a vertical rising sash, sash glass should be no higher than 18". Horizontal sliding panels on combination sashes must be closed when sash is raised vertically. The sash should remain closed when the hood is not in use.
5. Place chemicals and other work materials at least six (6) inches inside the sash.
6. Do not restrict air flow inside the hood. Do not put large items in front of the baffles. Large apparatus should be elevated on blocks. Remove all materials not needed for immediate work. The hood must not be used for storage purposes.
7. Never place your head inside the hood.
8. External air movement can affect the performance of the hood. Do not operate near open doors, open windows or fans. Avoid rapid body movements. Do not open the hood if there are cross-drafts or turbulence in front of hood. Do not open the sash rapidly.
9. If this hood is equipped with adjustable baffles, do not adjust the baffles without consulting the owner's industrial hygienist or safety representative.
10. Wear gloves and other protective clothing if contact with contaminants is a hazard.
11. Clean spills immediately.
12. If fumes or odors are present, stop operating the hood, close the sash and contact the owner's industrial hygienist or safety representative immediately.
13. It is recommended that this fume hood be tested and certified annually by the owner according to applicable industry and government standards.

### General Maintenance of Fume Hoods

Fume hood maintenance procedures consist primarily of cleanup, adjustment, lubrication, and replacement of worn, damaged or non-functioning parts. Lubrication of sash guides, cables, pulley wheels, and other working parts should be accomplished as required and replacement of broken, worn, or non-functioning parts as needed. The following items should be inspected and serviced at least semi-annually:

- Liner for condition and cleanliness
- Low air flow detectors
- Service fixtures and lights
- Double pulleys and belts
- Sash operation and counterbalance cables
- Velocity and pressure sensing detectors
- Low flow or no flow alarms, both visible (lights) and audible (horns or bells)
- Signal transmission for alarms designed to activate signals at more than one location
- Instrument verification of fume hood face velocity and determination of usage by observation and interview
- Duct work and blower

#### Warning

Use only fluorocarbon grease on blower since any other type is considered potentially hazardous.

#### Warning

Replace frayed or broken cables to avoid personal injury or damage to fume hood. Not all cable manufacturer's cables are of the same quality and cycle life. We warrant only cables furnished by Hamilton.

Cleanup should be accomplished by, or under the supervision of, a knowledgeable technician.

Flush all spills immediately using neutralizing compounds as required and clean thoroughly. Use good housekeeping in laboratory fume hoods at all times.

### Fume Hood Inspection Procedures

Safety considerations require a schedule of inspection and documentation be set up at least semi-annually for every laboratory fume hood.

An inspection record should be maintained. This record may be in the form of a label attached to the fume hood, or a log held by the laboratory director or health safety director.

Inspection procedures should include instrument verification of fume hood face velocity and a determination of usage by observation and interview. These procedures should also consist of a physical examination of liner condition and cleanliness, sash operation and condition, visible check of counterbalance cables, light operation and condition and service fixture function.

Inspection results should be recorded and reported to the proper authority for any required action.

Options, such as low air flow detectors, when installed, should be inspected at least annually. Where extremely hazardous or corrosive conditions exist or when filters are present in the system, the inspection frequency should be increased appropriately. Velocity and pressure-sensing detectors should be tested at each inspection. Low-flow or no-flow alarms of the visible (lights) or audible (horns or bells) type should be tested for correct operation at least at each inspection. Signal transmission for alarms designed to activate signals at more than one location should be verified at each location during each inspection. Promptly replace frayed or broken cables.

### Fluorescent Light Tube Replacement

1. Remove top front panel. Depress light shield and lift.
2. Grasp fluorescent tube(s), gently twist the tube and remove.
3. Install new light tube(s).
4. Reinstall top front panel.

### Fume Hood Valves

The valves used within fume hoods are needle valve type. If these wear, stainless steel cone and seat replacement kits can be ordered through your Hamilton distributor.

### Fume Hood Interiors

Fume hood liners are maintained by an occasional wash down with detergent and warm water. Stains and salt deposits can be removed with a weak acid solution (5%) or an appropriate solvent – **DO NOT USE ACETONE.**

**Side Frame Glass Replacement**

Side glass occasionally requires service. The glass may fog due to the condensation of chemical vapors, and such materials should be removed promptly by washing with water and detergent to prevent etching of the glass.

**Side glass may be replaced without disassembling panels. For front sash glass replacement, it will be necessary to remove the sash. See the following page for sash disassembly.**

1. Remove the outer portion of the moulding strip on all four sides of the frame. Use flat blade screwdriver to pry away moulding. Dispose of old glass and all portions of the moulding strip.

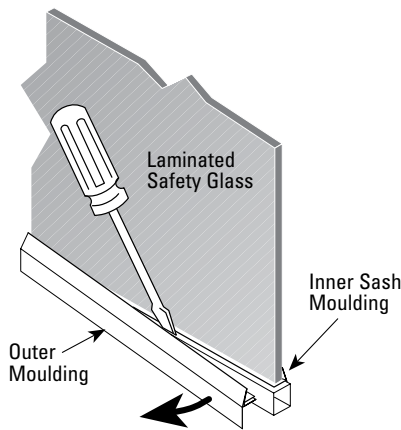

2. Place the new moulding strip over the frame.
3. Place the new glass onto the inner moulding.

4. Press the outer moulding strip into the groove of the inner strip.

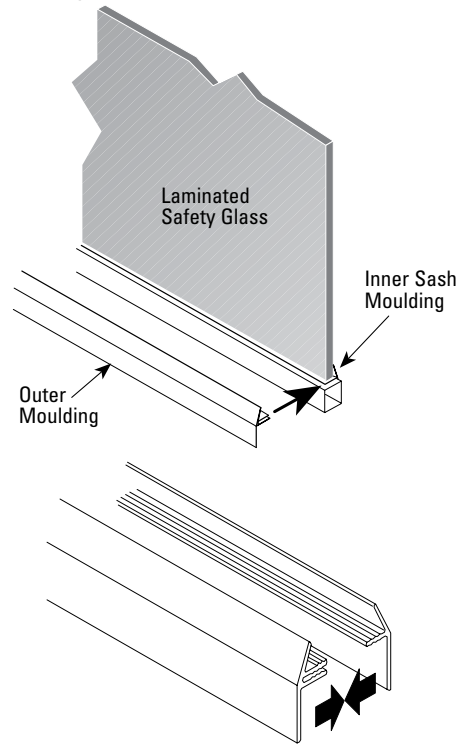

**Cable Replacement**

**Special parts, options, and accessories should be maintained as required.**

Follow the steps in the Installation section for cable replacement.

**Warning**

If cable is frayed or damaged, it must be replaced to avoid personal injury or damage to the fume hood. We recommend replacement cables be ordered from Hamilton to ensure cable quality.

**Sash Glass Replacement**

1. Remove front panels, see Steps 18 and 19 on page 8.
2. Remove two corner posts, see Step 16 on page 7.

**Warning**

Turn electrical power OFF before removing corner posts.

3. Remove the nut from each cable end and detach cable from sash, see Step 14 on page 7.
4. Remove sash and replace glass.
5. When installing sash, make sure sash is even and balanced. Adjust cable accordingly.
6. Reverse Steps 1, 2 and 3 above.

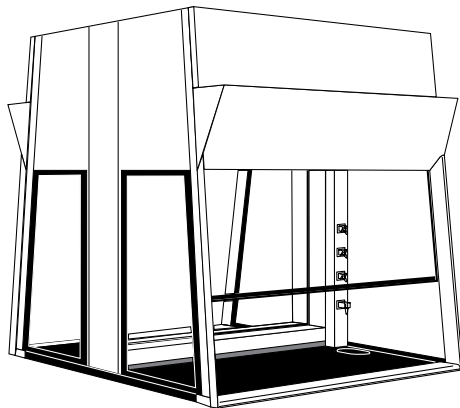

**Blower Adjustments**

1. Remove housing over motor blower assembly.
2. Loosen the four (4) bolts [A] which hold the motor mounting plate stationary so that the plate has a vertical movement, as shown in illustration below. This should be done so that a later adjustment for correcting belt tension can be made.
3. Make all adjustments ONLY with the outside half sheave [B] on the driving shaft.
4. To increase the RPM of the blower, increase the diameter of the driving sheave by loosening the Allen screw [C] and turning the outside half-sheave toward the motor. Tightening the Allen screw to the flat portion of the threaded shaft then fixes the diameter of the sheave.
5. To decrease the RPM of the blower, decrease the diameter of the driving sheave by loosening the Allen screw [C] and turning the outside half-sheave away from the motor. Tightening the Allen screw to the flat portion of the threaded shaft then fixes the diameter of the sheave.
6. Correct belt tension (side play 1/2" to 3/4") can now be set by adjusting the loosened motor mounting plate and tightening the four (4) bolts.

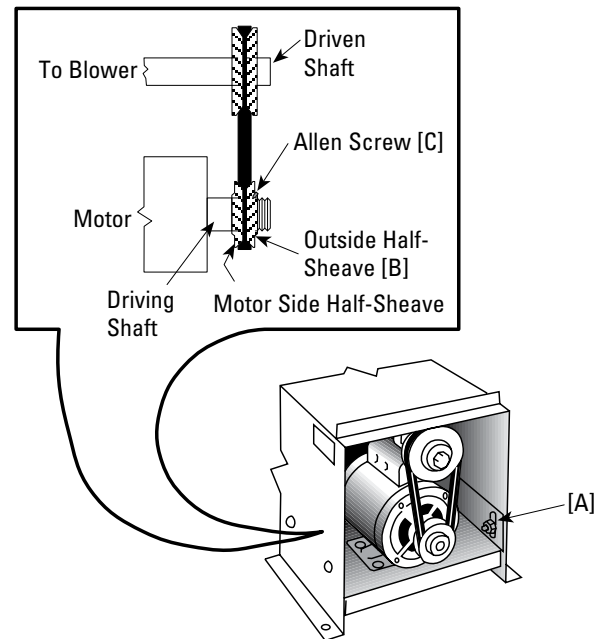

**Sheave** = Pulley  
**Driven** = Attached to blower shaft  
**Driving** = Attached to motor shaft

**Fume Hood Evaluation in the Field**

It is recommended that the user make provisions to have the following tests performed on all laboratory fume hoods. These tests should be performed by qualified personnel to verify proper operation of the fume hoods before they are put to use. Fume hood testing should be performed after the installation is complete, the building ventilation system has been balanced, and all connections made. Any unsafe conditions disclosed by these tests should be corrected before using the fume hood.

**Test Procedures**

**Test Conditions**

Verify that building make-up air system is in operation, the doors and windows are in normal operating position, and that all other fume hoods and exhaust devices are operating at designed conditions.

**Room Conditions**

Check room condition in front of the fume hood using a thermal anemometer and a smoke source to verify that the velocity of cross drafts does not exceed 20% of the specified average fume hood face velocity. Any cross drafts that exceed these values shall be eliminated before proceeding with the fume hood test.

**Equipment List**

- (a) A properly calibrated hot-wire thermal anemometer similar or equal to Alnor model no. 8500.
- (b) A supply of 1/2 minute smoke bombs.
- (c) A bottle of titanium tetrachloride and a supply of cotton swabs or other recognized device for producing smoke.

**CAUTION**

Titanium tetrachloride fumes are toxic and corrosive. Use sparingly, avoid inhalation and exposure to body, clothing and equipment.

**It must be recognized that no fume hood can operate properly if excessive cross drafts are present.**

**Face Velocity**

Determine specified average face velocity for the fume hood being tested. Perform the following tests to determine if fume hood face velocities conform to specifications. With the sash in normal operating position, turn ON the exhaust blower. The face velocity shall be determined by averaging the velocity of six readings taken at the fume hood face. Readings shall be taken at the centers of a grid made up of three sections of equal area across the top half of the fume hood face and three sections of equal area across the bottom half of the fume hood face.

**If not in accordance with specified face velocity, refer to Troubleshooting section on page 17, for aid in determining the cause of variation in air flow. If face velocity cannot be corrected to that which is specified, reclassify fume hood to conform to actual face velocity. Shut off the auxiliary air when testing an auxiliary air fume hood.**

**Sash Operation**

Check operation of the sash by moving it through its full travel. Sash operation shall be smooth and easy. Vertical rising sashes shall hold at any height without creeping up or down.

**Air Flow**

**Fume Hoods**

Turn fume hood exhaust blower on. With sash in the open position, check air flow into the fume hood using a cotton swab dipped in titanium tetrachloride or other smoke source. A complete traverse of the fume hood face should verify that air flow is into the fume hood over the entire face area. A reverse flow of air indicates unsafe fume hood operation. Consult the Troubleshooting section on page 17, for possible causes and take corrective action. Move a lighted smoke bomb throughout the fume hood work area directing smoke across the work surface and baffle. Smoke should be contained within the fume hood and be rapidly exhausted.

**Low Air Flow Monitor**

On fume hoods with low flow warning devices, verify that monitor functions properly and indicates unsafe conditions.



**ANSI/ASHRAE 110-1995**

The previous test is based on the SEFA-1.2 1996 standard. Although the test is an excellent quick indicator of proper hood air flow it does not actually indicate the capture efficiency. For this reason Hamilton has adopted the ASHRAE 110-1995 test standard. This test is used to establish an (as manufactured) "AM" performance rating.

This same procedure can be performed in the field under (as used) "AU" conditions which can vary considerably. The capture rate in P.P.M. can be related to the OSHA threshold limit levels by an industrial hygienist or qualified lab technicians to determine proper hood usage.

The performance of a laboratory fume hood in providing protection for the worker at the face of the hood is strongly influenced by the laboratory room ventilation, and by other features of the laboratory in which it is installed. Therefore, there arises a need for a performance test which can be used to establish an "as manufactured" and an "as used" performance rating, including the influences of the laboratory arrangement and its ventilation system.

The test presumes a conditioned environment. No test can be devised which would, conducted once or infrequently, (viz., annually), reflect the results which would be obtained in a non-conditioned laboratory with various conditions of windows, wind velocity, etc.

This procedure is a performance test method.

It remains for the user, the hygienist, or the applications engineer to specify what level of hood performance is desired or required. It should be noted that the performance test does not give a direct correlation between testing with a tracer gas and operator exposures. Many factors, such as the physical properties of the material, the rate and mode of evolution, the amount of time the worker spends at the face of the hood, and several other factors must be integrated, by a trained observer, into a complete evaluation of worker exposure. The performance test does, however, give a relative and quantitative determination of the efficiency of hood capture under a set of strict, although arbitrary, conditions. The same test can be used to evaluate hoods in the manufacturer's facilities under (presumably) ideal conditions, or under some specified condition of room air supply.

The test may be used as part of a specification once the appropriate release rate and required control level are determined. If so used, an "AM" (as manufactured) specification places a responsibility on the hood manufacturer, and an "AU" (as used) specification places responsibilities on others, viz., the designer of the room air supply, the designer of the room layout, etc.

The test sheet attached to the hood reflects hood performance parameters. This sheet represents "AM" testing.

Hamilton strongly recommends the ASHRAE 110-1995 test procedure be subjected to this hood under "AU" (as used) conditions.

Refer to ASHRAE standard 110-1995 or contact Hamilton for further information.

If for some reason the above test cannot be performed at the job site, Hamilton strongly suggests use of the SEFA-1.2 1996 test procedure as minimal proof of proper hood performance.

This test consists of a face velocity grid test and a smoke test procedure.

Hamilton recommends at least annual verification that the above criteria is subjected to and met by all hoods at your particular facility.

Field Evaluation of Laboratory Fume Hoods

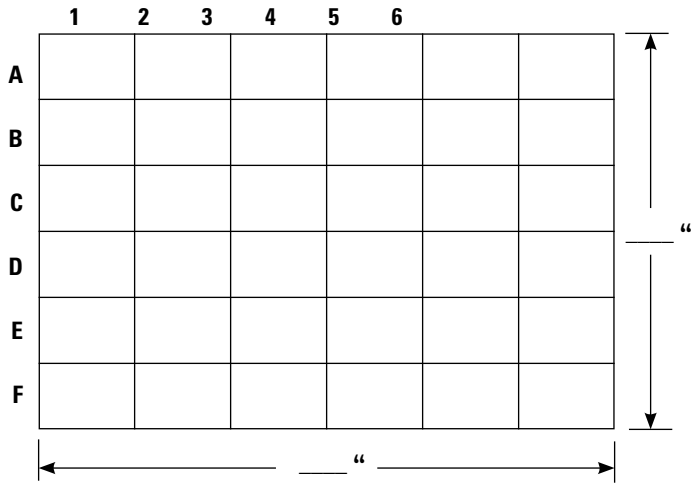

Project Name \_\_\_\_\_

Location \_\_\_\_\_

Order Number \_\_\_\_\_

Room \_\_\_\_\_ Item \_\_\_\_\_

Fume Hood Identification \_\_\_\_\_

Model \_\_\_\_\_

Sash Operation \_\_\_\_\_

Light Operation \_\_\_\_\_

Baffle Operation \_\_\_\_\_

Services:  A  G  V  W  NITROGEN  
 STEAM  OTHER \_\_\_\_\_

ALARM CONDITION: FUNCTIONAL \_\_\_\_\_  
 NON-FUNCTIONAL \_\_\_\_\_

SMOKE TEST: POSITIVE \_\_\_\_\_  
 NEGATIVE \_\_\_\_\_

**TOTAL OF READINGS** \_\_\_\_\_ = \_\_\_\_\_  
 Number of readings \_\_\_\_\_ AVG.  
 \_\_\_\_\_ X  
 \_\_\_\_\_ + \_\_\_\_\_ = \_\_\_\_\_  
 Sq. Ft. of Opening Bypass (If Any) Total Sq. Ft.  
 Total CFM = \_\_\_\_\_  
 (Avg. X Total Sq. Ft.)

Project Name \_\_\_\_\_  
 \_\_\_\_\_  
 \_\_\_\_\_  
 \_\_\_\_\_  
 \_\_\_\_\_  
 \_\_\_\_\_  
 \_\_\_\_\_  
 \_\_\_\_\_  
 \_\_\_\_\_  
 \_\_\_\_\_

I certify that the above results were obtained on \_\_\_\_\_ by \_\_\_\_\_  
 Evaluation procedures conducted by \_\_\_\_\_  
 Name Title

When fume hood test procedures detect an improper function, the cause is typically due to:

- (a) Insufficient quantity of air flowing through the fume hood;
- (b) Room cross drafts blowing into or across the face of the fume hood; or
- (c) A combination of (a) and (b).

Following are suggestions to troubleshoot the problem.

#### ■ Room Cross Drafts

Air moving through an open door located adjacent to the fume hood can cause cross drafts. An open window or a room air supply located to one side or across from the fume hood can also cause disturbing cross drafts.

High velocity air from ceiling-mounted diffusers can cause a flow of air down and into the top half of the fume hood face which then causes reverse flows of air out of the bottom half of the face.

#### ■ Insufficient Air Flow

One or more of the following conditions may exist; each condition should be checked and eliminated if possible, to determine what conditions may exist:

- (a) Inaccurate face velocity readings. Check airflow velocity meter type. Is the instrument recommended for low air velocities in the 50 to 100 feet per minute ranges? When was it calibrated last?
- (b) Verify readings with another air velocity meter or by checking air volume using a pitot tube traverse or exhaust duct.

Before contacting a service rep to assist with troubleshooting, answering the following questions will help identify where the problems have originated.

Who stated that the unit did not operate properly?

Confirm the following:

- That person's position
- That person's employer

What tests were performed?

Confirm the following:

- Instruments used
- When it was last calibrated
- Calibration results

What is the fume hood type?

Confirm the following:

- Fume hood model
- Fume hood size

Is the location of fume hood acceptable?

Are cross currents present?

- Determine whether there is traffic past the fume hood.

Is adequate free or make-up air available?

Confirm the following:

- Whether the air is readily available
- The supply source of air
- Whether it can be altered or cut off

Did the fume hood ever function properly?

- Determine whether authorized modifications been made and when.

Have recent changes been made in the laboratory heating/cooling system?

- If so, describe.

# **DO NOT DISCARD IMPORTANT TEST AND CALIBRATION DATA ENCLOSED!**

**TO BE REMOVED ONLY BY HOOD USER**

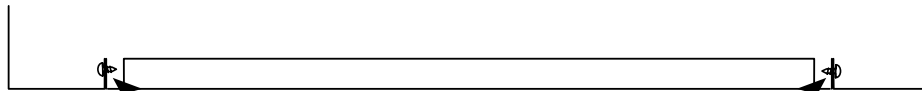

**Remove Shipping Screws From Top  
of Front Panel After Placing Hood in  
Position on Work Surface**