

SafeAire® Fume Hoods

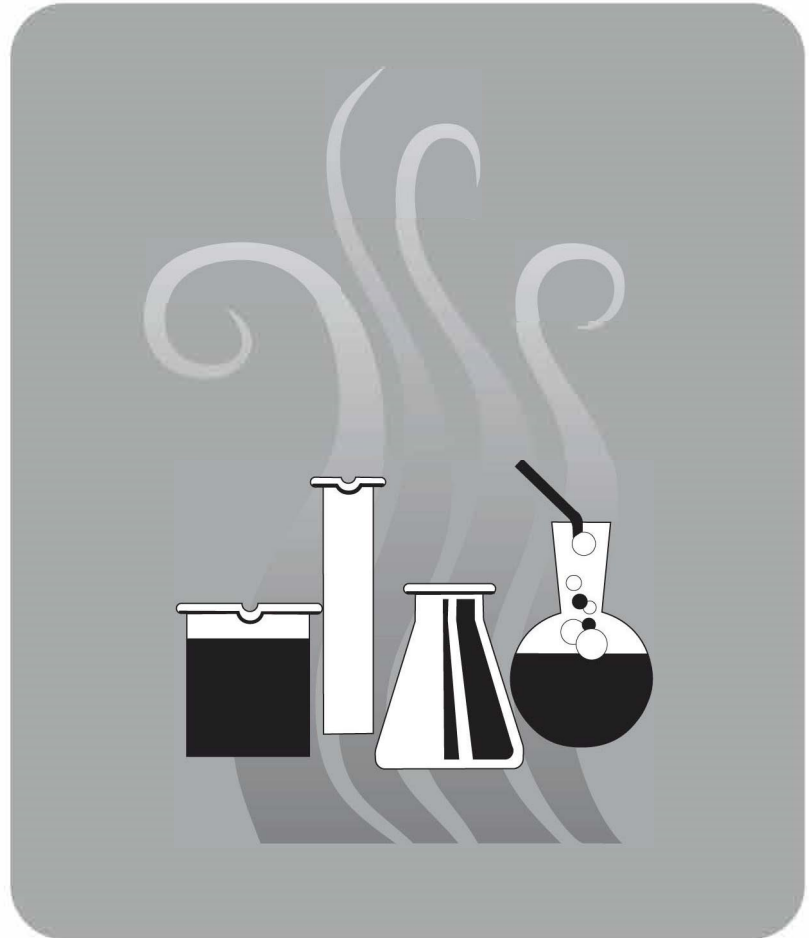

Operation, Maintenance and Installation Instructions

GENERAL INFORMATION

Hamilton is pleased to have had the privilege of furnishing your laboratory equipment. This is a major investment, and your equipment is built to withstand extremes of temperature, stress and corrosion provided you give it reasonable care.

This manual gives you full information for the operation and care of fume hoods and other Hamilton equipment items.

Utility and fine appearance can be assured for many years by following simple procedures. A regular schedule of maintenance will be most effective.

Table of Contents

GENERAL INFORMATION	2-3
General	2
Perchloric Acid Hoods	3
Hood Identification	3
INSTALLATION	4-19
Fume Hood Superstructures	4
Floor-Mounted Fume Hoods	5-9
HOPEC IV Fume Hoods	10-11
Air Chamber, Auxiliary Air Fume Hoods	11
Baffles	12-13
Safety Shields	14-15
Blower Enclosures	16-18
Fume Hood Monitors	19
Exhaust Filter Assembly	19
Minihelic Gauge	19
WARNING/OPERATING INSTRUCTIONS	20
MAINTENANCE AND ADJUSTMENTS	21-27
General Maintenance	21
Fume Hood Inspection	21
How to Replace Fluorescent Light Tube	21-22
Servicing Fume Hood Fixtures	22
Cleaning Fume Hood Interiors	22
Replacing Sash Glass and Cables	23-25
Servicing Supply Chamber Air Filter	26
Exhaust Filter Replacement	26
Blower RPM Adjustments	27
Manometer, Monitoring Exhaust Filters	27
FIELD TESTING	28-30
TROUBLESHOOTING	31

GENERAL

Fume hoods are exposed to extremes of temperature, reagent fumes and working surface abuse. Regular care will prolong service life and insure safe working conditions.

The exhaust system and blower of a fume hood must function properly for safety. Maintenance personnel should service the fan and motor assembly regularly, lubricate as required, and make sure that the exhaust system is free from obstructions. Semiannually, accumulated deposits should be removed from the impeller blade and housing.

A simple test with lighted match or smoke will show if the air is being drawn into the hood. More accurate checks of air velocity can be made with a thermal anemometer. See Inspection and Field Evaluation procedure.

Always place equipment and apparatus as far back into the fume hood as possible since this provides greater assurance of proper fume collection and removal.

Large, bulky apparatus or equipment should be placed in the fume hood to permit air flow around it, and never placed so as to interfere with the operation of the baffle system. Raise large items an inch or two above work surface. Spilled liquids, acids, or corrosive materials should be immediately wiped up and the surface neutralized with water or the proper neutralizing agent so as to prevent damage to the work surface and the hood interior or to apparatus and equipment installed in the hood.

Remember that special fume hoods are required for the handling of Perchloric Acid. See next page.

PERCHLORIC ACID HOODS

The properties of perchloric acid require that a specially designed fume hood be set aside for exclusive use with this material. The hood is equipped with a cold water spray device for washdown of the interior surfaces. A trough is placed across the back of the hood for collection and disposal of washdown waters. Operating personnel should be well trained in the proper handling techniques and be familiar with the characteristics of this material.

Frequency of washdown, both hood interior and exterior system, is determined by the usage and concentration of reagents. This can range from a weekly procedure to one that occurs after every use. Washdown should always be followed by an inspection to verify that all areas are clean and that the wash system is functioning properly.

Some of the hazards of perchloric acid which justify the use of a special hood are:

1. Perchloric acid is a very strong acid, capable of producing severe burns when in contact with skin, eyes or respiratory tract.
2. As an aqueous solution, it can cause violent explosions if improperly handled.
3. It reacts with other substances to form unstable materials which are susceptible to exploding either by impact, friction, or spontaneous combustion.

Persons using perchloric acid should be thoroughly familiar with its hazards. Many reported laboratory accidents have involved less than one gram of reactant. Listed below are some common safety practices that should be followed:

- Spilled perchloric acid should be thoroughly washed away with large amounts of water.
- The use of organic chemicals or materials in the hood should be avoided.
- Goggles or other effective eye protection should be used whenever possible, as well as utilization of the fume hood sash for additional safety.
- Gas flames or oil baths should not be used within the hood.
- Organic chemicals should not be kept in storage areas set aside for perchloric acid storage.
- A schedule should be made for regular washdown and inspection of hood interior, ductwork and blower to guard against a build-up of dangerous perchloric materials.
- Only a fluorocarbon grease should be used as a blower lubricant, since any other type is to be considered potentially hazardous.
- Washdown procedure should be performed after completion of usage with all apparatus removed from hood.

HOOD IDENTIFICATION

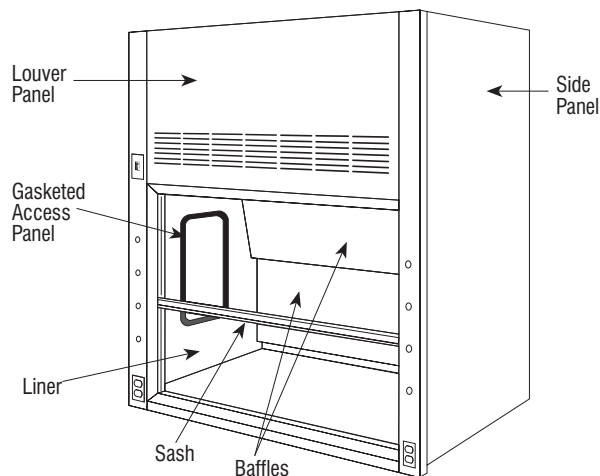

INSTALLATION**FUME HOOD SUPERSTRUCTURE INSTALLATION****Side Enclosure Panels**

1. Lower the side panel into the side frame of the fume hood superstructure, engaging the frame's lower lip. While pressing down on the two black catches, rotate the side panel and engage the frame's upper lip. Gently apply additional pressure to the panel and release the catches to secure the panel to the hood.

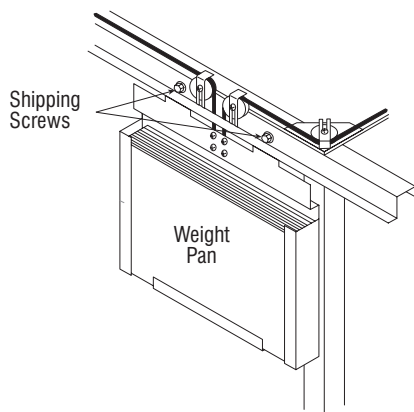
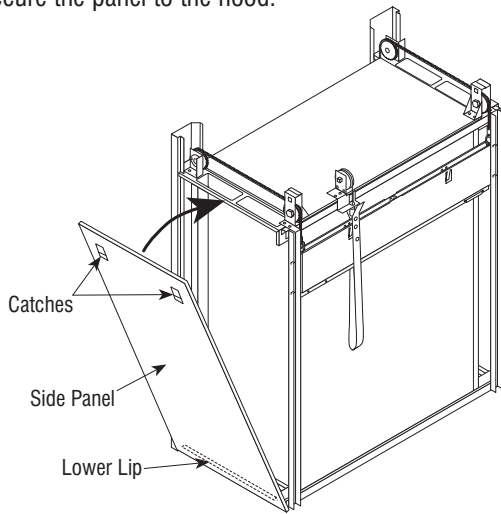

2. Remove two (2) shipping screws that secure the counterbalance weight pan to the rear top rail.
3. Remove screws from sash hold-down clips. Open the sash and remove blocking, being careful not to damage sill or baffles.

NOTE: Baffles can be installed at this time, or after the hood is in place on the work surface. See Pages 12–13.

4. Remove shipping screws holding the fume hood frame to the skid. Save four (4) of these screws, No. 10 X 5/8", to secure hood to the work surface.
5. Place the fume hood on the work surface taking care to protect the work surface.

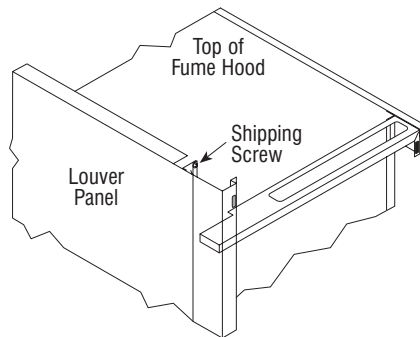

6. Remove two (2) shipping screws from the top of the louver panel. **These screws must be removed to allow future access to the fluorescent lights.**
7. Check the following items:
 - That the counterweight operates free of obstructions.
 - That the cables align properly in the pulleys.
 - That there is proper horizontal sash alignment and counterweight balance.
 - That the sash does not bind in the sash guides.

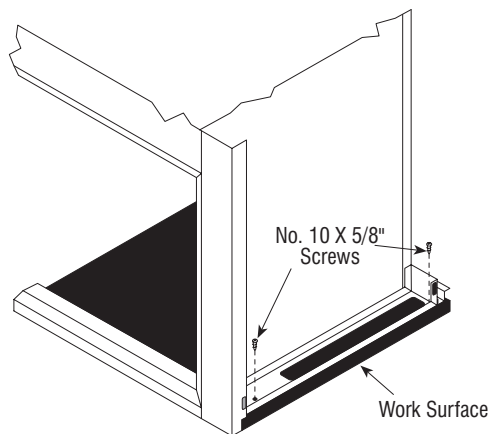

8. Drill two (2) each 1/8" diameter pilot holes at each side structural frame into the work surface and secure same with four (4) No. 10 X 5/8" screws saved from the shipping skid.
9. Reinstall end panels.
10. Caulk hood to work surface with silicone sealant.

ASSEMBLY INSTRUCTIONS FOR KNOCKED-DOWN FLOOR-MOUNTED FUME HOODS

General - When receiving fume hood assemblies, inspect for damage immediately. If damage is noted, request the delivering carrier to note and describe damage on bill of lading prior to your signature. Notify carrier immediately and request inspection.

Open boxes and crates and examine for hidden damage. If damage is noted, save containers and request an inspection.

Move all components to installation area.

1. Attach left-hand side assembly (2) to back assembly (1). Take back panel assembly and stand vertically, as shown, and slide into end assembly. (Angle flange of end assembly fits between back panel and horizontal members of back assembly). Secure each corner with two #8 X 5/8" PPHSMS at mating holes on top and bottom corners of joined assembly. Repeat steps with right-hand end (3). Attach each baffle support with two each #8 X 3/4" PPHTCS through back panel into support. Do not over-tighten.

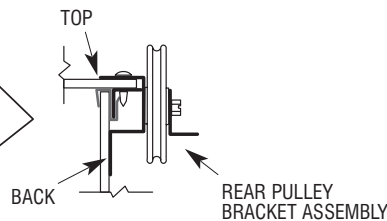
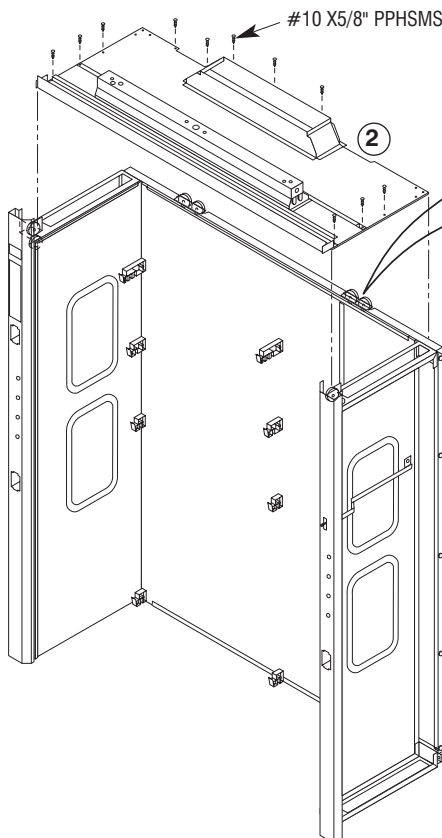
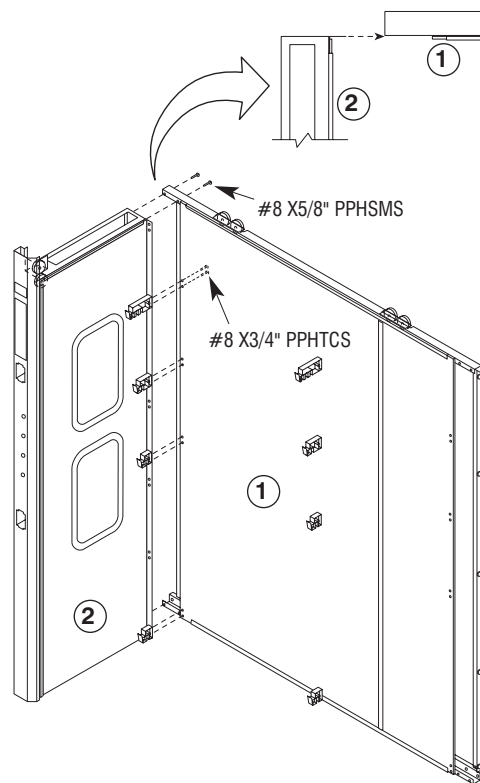

2. Attach top assembly (4), as shown at left, to back and ends with eleven (11) #10 X 5/8" PPHSMS. Top assembly fits underneath right-hand rear pulley bracket assembly. Secure exhaust collar to rear rail.

INSTALLATION**ASSEMBLY INSTRUCTIONS FOR KNOCKED-DOWN FLOOR-MOUNTED FUME HOODS**

3. Attach left rear pulley assembly (5) using three (3) #8 X 5/8" PPHSMS. Attach right rear plate assembly (6) using three (3) #8 X 5/8" PPHSMS. Slide 3" sheave (7), then 2" sheave (8) over threaded stud. Loosely fasten with 1/4-20 KEPS nut. Install right-hand cable retainer support (27) using two (2) #8 X 5/8" PPHSMS.

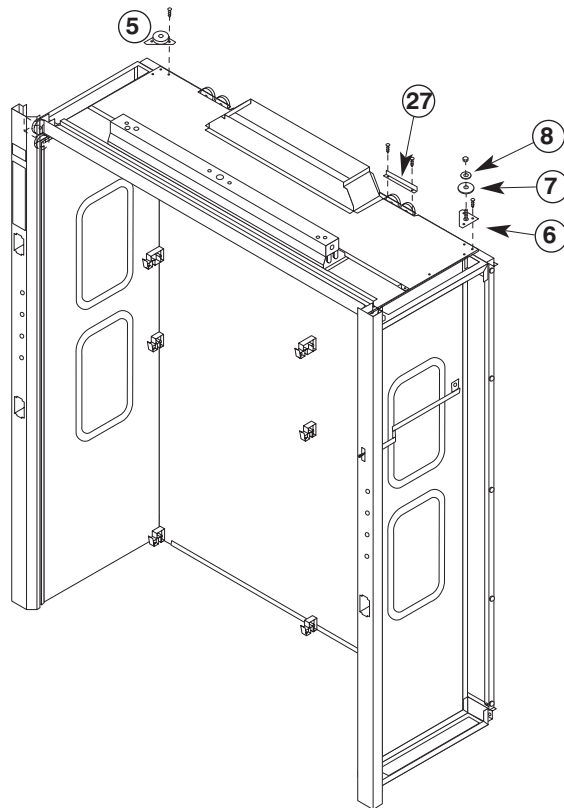

4. Remove pieces of tape (9) holding top panel extrusion in place. Lift header panel (11) and place bottom in right-hand and left-hand baffle clips (10). (Short header panel - bypass hoods, does not have baffle clips). Bottom extrusion on header panel faces outward. Fasten top of header panel to angle with #8 X 5/8" PPHSMS.

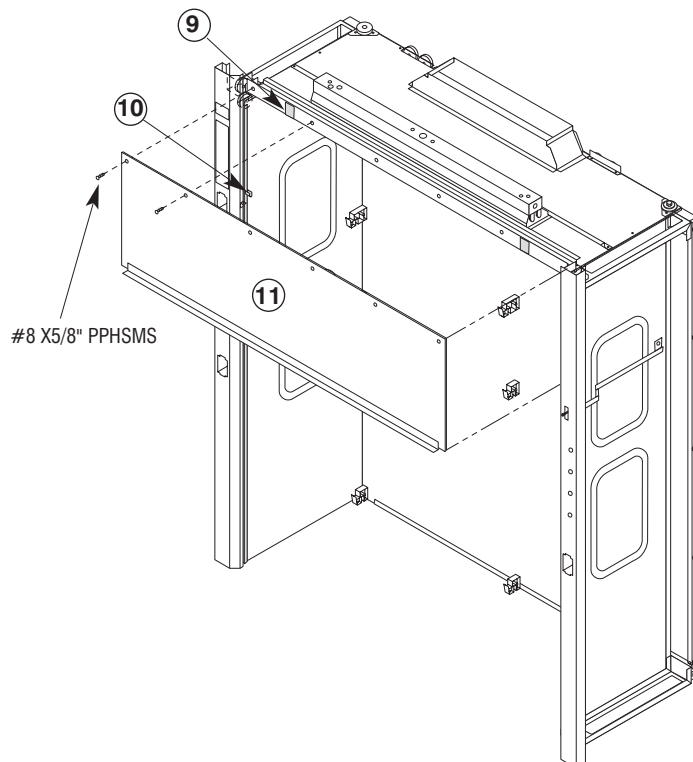

ASSEMBLY INSTRUCTIONS FOR KNOCKED-DOWN FLOOR-MOUNTED FUME HOODS

5. Install four (4) baffles as indicated. Install baffles with notches down. Proceed from bottom to upper baffle (12, 13, 14, 15). If remote control is included with hood, place intermediate baffle (14) in already installed remote control baffle arm (16). Lower and intermediate baffles are the same size. Insert upper baffle into collar extrusion per Detail "B". Test remote control baffle adjuster for function.

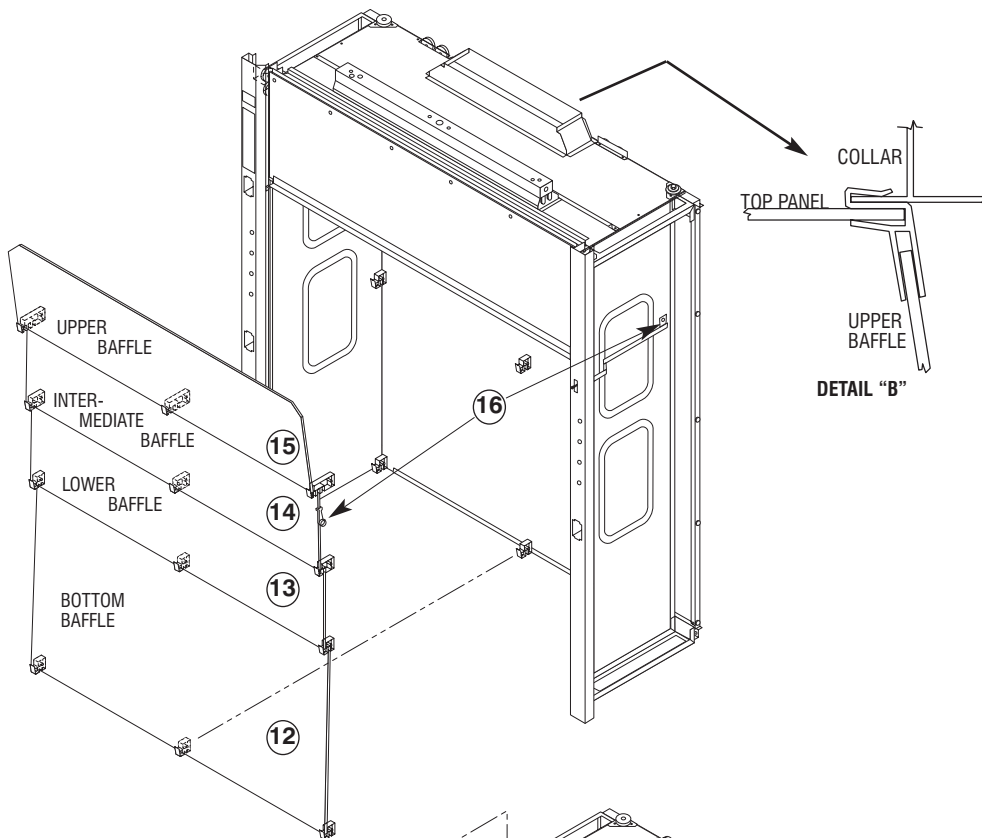

6. Install rear top sash (17) in right-hand and left-hand rear sash guides. Sashes are installed from the top of the hood. Lower the sashes into the sash guides. The rear top sash must be located above the stops located approximately half way up the sash guides. Locate the front bottom sash (18) in the front right-hand and left-hand sash guide. Remove the tape from the cable assemblies that are taped to each sash. Uncoil the cable and place on top of hood.

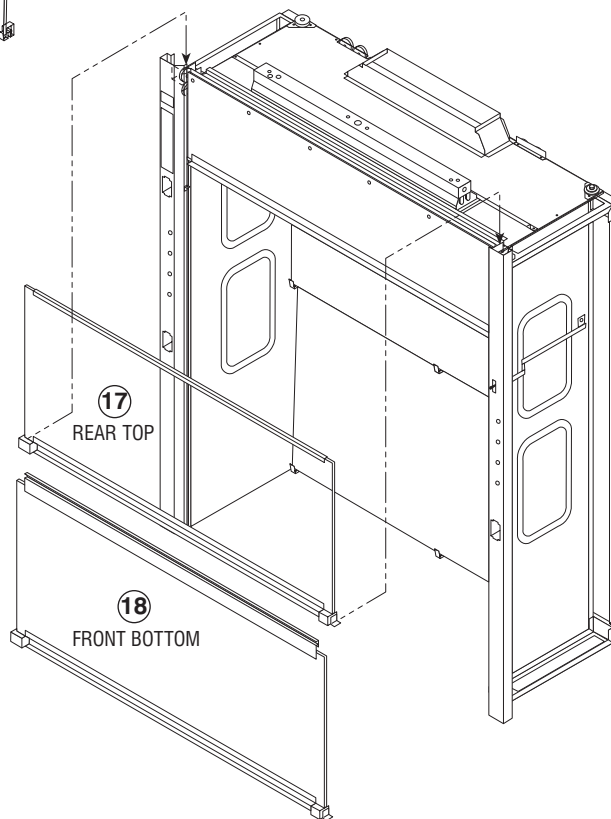

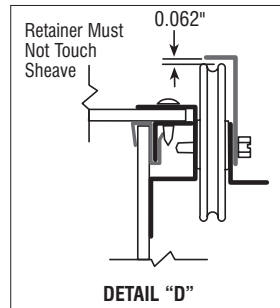
INSTALLATION**ASSEMBLY INSTRUCTIONS FOR KNOCKED-DOWN FLOOR-MOUNTED FUME HOODS**

7. Before hood is pushed against wall, place top rear sash cable (19) over pulleys as shown in instructions. Brace bottom of sash about 6" above sash stops, with 2 x 4 or similar, to allow for a more manageable cable. Attach weight (20) to cable, Detail "C". Fasten cable clamp (23) and two (2) 1/4-20 X 3/4 HHTCS (24), do not completely tighten screws. Repeat process with front bottom sash cable (21). Test sash level, alignment and travel. Make any necessary adjustment. If necessary, fine tune weight pan. Fasten clamp screws tightly. Attach all cable retainers (22, 25). Do not over-tighten retainers – allow 1/16" for pulley movement. See Detail "D". The nylon tape (26) at the cable loops at the ends of the sash pull is no longer necessary, remove and discard.

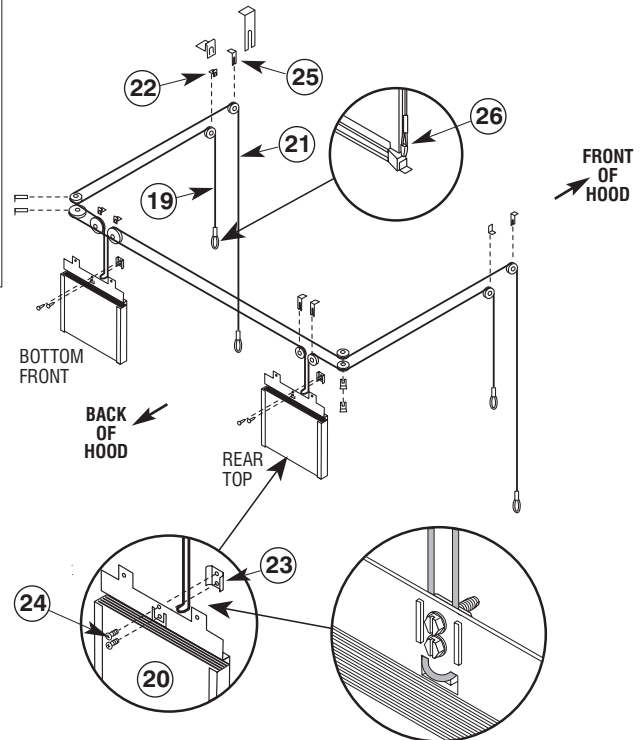

8. Position fume hood in a permanent location. Have qualified personnel attach all required electrical devices and plumbing fixtures. Lower the side panel (27) onto the side frame of the fume hood, engaging the frame's lower lip. While pressing down on the two black catches, rotate the side panel and engage the frame's upper lip. Gently apply additional pressure to the panel and release the catches to secure the panel to the hood.

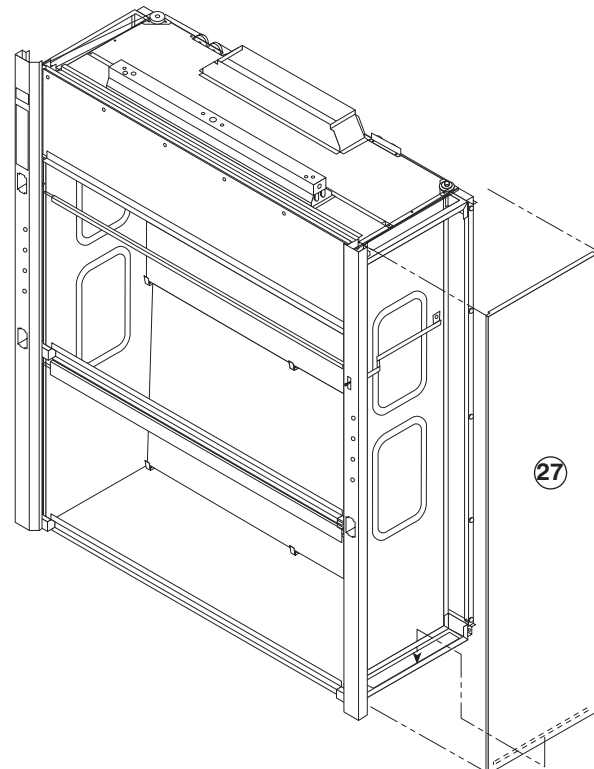

ASSEMBLY INSTRUCTIONS FOR KNOCKED-DOWN FLOOR-MOUNTED FUME HOODS

9. Attach lintel panel (28) to front of hood. Engage top of panel with studs on top, inside of front access panel and fasten bottom of panel to angles on front access panel with #8 X 5/8" PPHSMS. Drive screws as shown.
10. Make sure hood is square and aligned.

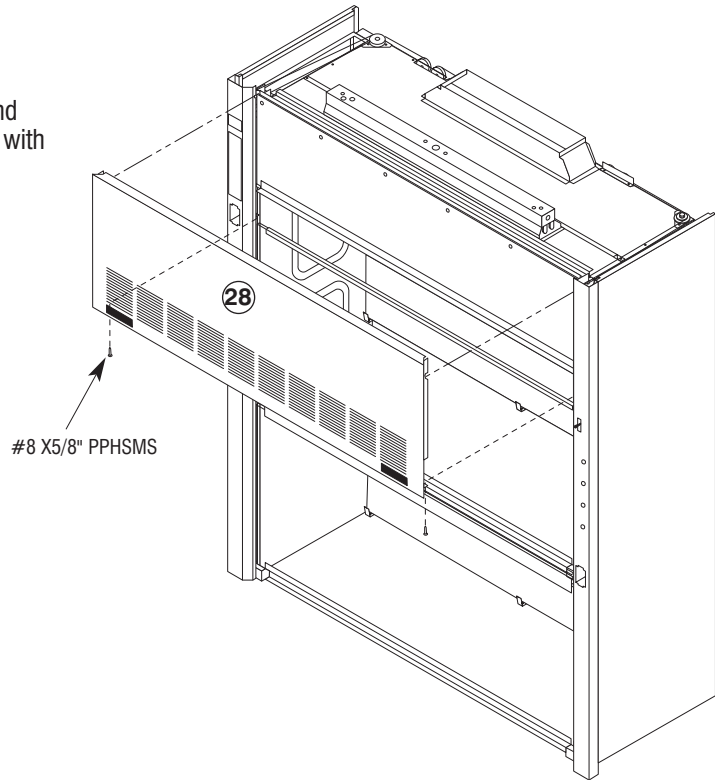

INSTALLATION

HOPEC IV FUME HOOD INSTALLATION

1. Install and level two fume hood base cabinets with rear fillers and kneespace panel as required.
2. Depending on height requirements, install either the top filler frame assembly alone or in combination with the optional-height filler frame.

If the **TOP FILLER FRAME ONLY IS REQUIRED**, insert rough assembly into top filler frame and locate front lower edge of trough flush with cabinet or optional height filler. Secure to the base cabinet using eight (8) No. 10 X 5/8" PPHSMS through the side returns of the Top Filler Frame into the front and rear returns of the base cabinet.

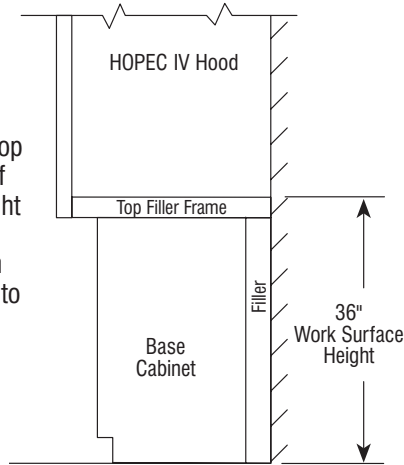

End view showing HOPEC IV hood, Top Filler Frame and Base Cabinet.

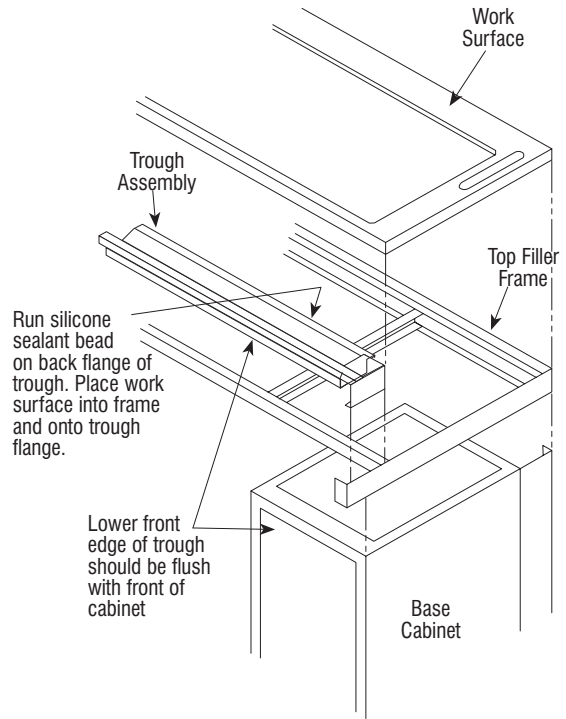

If the **OPTIONAL HEIGHT FILLER FRAME IS REQUIRED**, it is installed by aligning it's bottom 3/4" return on the base cabinet and securing with (4) No. 10 X 5/8" PPHSMS screws. Insert through assembly into Top Filler Frame and locate front lower edge of trough flush with cabinet or optional height filler. Attach the Top Filler Frame to the Optional Filler Frame using eight (8) No. 10 X 5/8" PPHSMS through the side returns of the Top Filler Frame into the front and rear returns of the base cabinet.

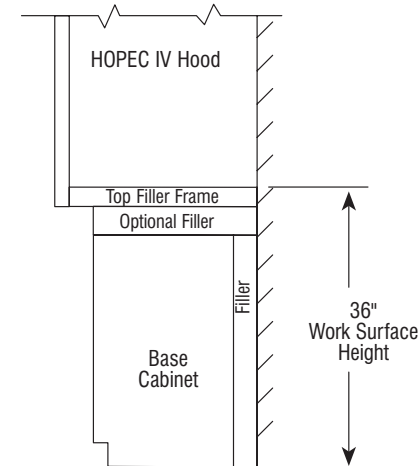

End view showing HOPEC IV hood, Top Filler Frame, Optional Height Filler and Base Cabinet.

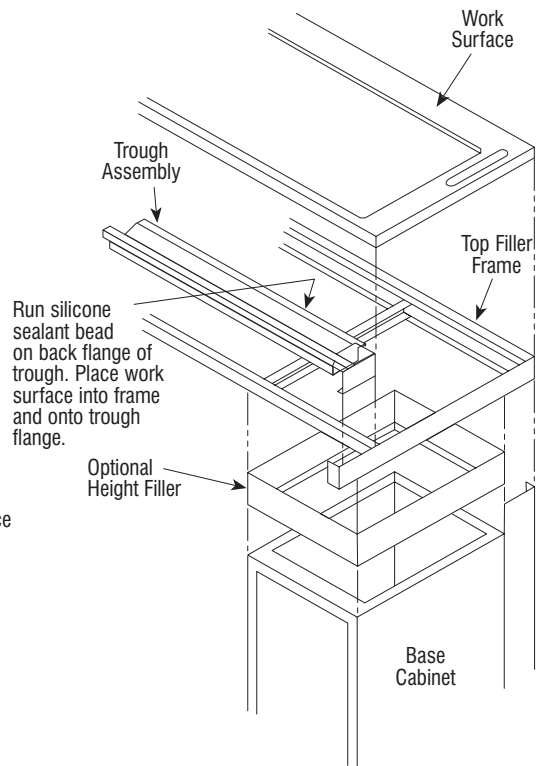

Dimensions are nominal and illustrations and specifications are based on the latest product information available at the time of publication. The right is reserved to make changes at any time without notice.

HOPEC IV FUME HOOD INSTALLATION (cont..)

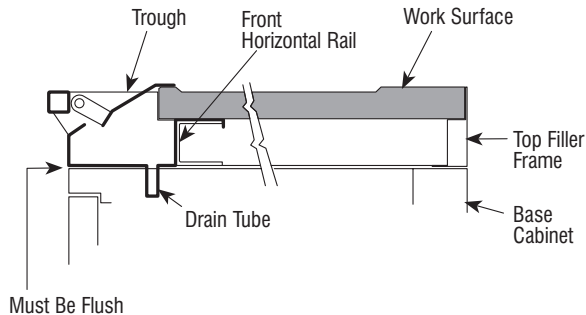

- Set the fume hood trough onto the top filler frame. The rear edge of the trough will set over the front horizontal rail and the return edge on the trough will secure it in place.

NOTE: If a drain tube is required, it should be installed at this time. The tube is located at the left end of the trough and is fed through the top of the left hand base cabinet into a one gallon container.

- Install poly vent, if required, through pre-drilled holes in the backs of base cabinets. The tail piece of the vent is supplied with a double compression assembly to lock it in place.
- Seal the top edge of the trough assembly with a RTV silicon or other applicable sealer and then place the fume hood work surface into the Top Filler Frame. If base cabinet poly vents are used, align them to the pre-cut holes in the work surface.
- Install cupsinks if required. The fume hood base cabinets are supplied with pre-punched holes in the back panels above the stone liner for cupsink drains. Cupsink assemblies are supplied with the sink, an extension pipe, an elbow, and a pipe section that protrudes through the hole in the base cabinet back. The cupsink assembly is designed to fit two conditions.
 - When the fume hood assembly is supplied with the Optional Height Filler Frame, the cupsink assembly is fished through the sink cutout hole in the work surface and the drain line hole at the rear of the base cabinet.
 - When the fume hood is supplied with only the Top Filler Frame, the extension pipe below the cupsink is removed to maintain alignment with the base cabinet rear drain hole. The pipe extension should be saved in the event that the Optional Height Filler Frame be required at a later date.
- Move the HOPEC IV fume hood to the area of installation. Perform Steps 1–10 on Page 4.

INSTALLING AIR CHAMBER – AUXILIARY AIR FUME HOODS

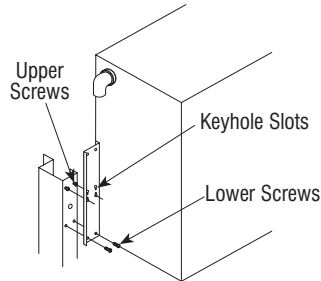

- With hood on work surface, lower air make-up tubing to expose four (4) mounting holes in galvanized frame. Install screws into upper mounting holes, tightening halfway.
- Lift the air chamber up and onto the upper mounting screws. Two people are required for this procedure, one at each end of the chamber. While chamber is supported by the upper screws, install the lower mounting screws. Tighten all mounting screws securely.
- Lift make-up air tubing back up and into PVC elbows at ends of air chamber. Secure with screws provided with elbows.

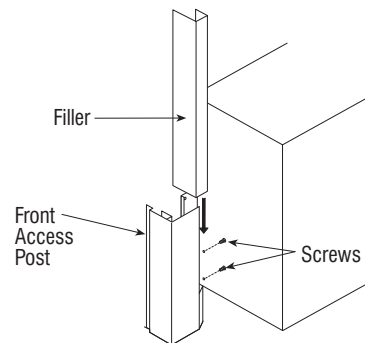

- Install the left- and right-hand fillers along with two (2) screws each side, accessible from inside the air chamber.

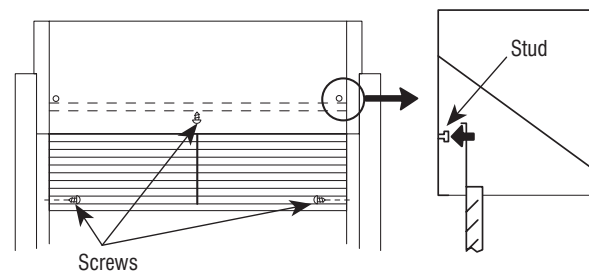

- Install louver panel by hooking top edge onto studs in chamber. Secure with three (3) screws.
- Install sash enclosure by hooking top frame flange onto offset angle on back of air chamber.

INSTALLATION**BAFFLE INSTALLATION AND ADJUSTMENT**

Hamilton provides two choices of baffle design concepts:

1. Multi-position fixed.
2. Remote exterior control

Baffle Installation

Install baffles according to information on the next page.

See label located on interior right-hand wall for repositioning instructions for Multi-Position Fixed Baffle. See label located on right front post for Remote Exterior Baffle adjustment instructions.

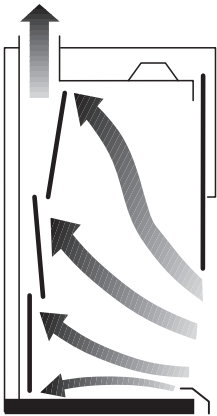

A – Normal Exhaust Requirements

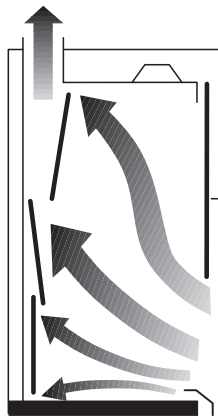

B – High Heat Loads or Lighter-Than-Air Gases

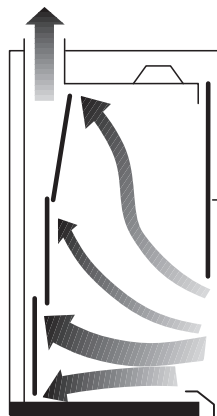

C – Heavier-Than-Air Gases and Surface Fumes

Baffle Adjustment

Hamilton fume hoods have three baffle settings:

- A. Normal or Average.
- B. Lighter-than-Air or high thermal loading.
- C. Heavier-Than-Air

Position **A** is for normal exhaust requirements. Locate baffle in center of movement arc. All slots are functional. This baffle position is suitable for most fume generating activities.

Baffle position **B** is for lighter-than-air gases, or high heat loads. The top slot is open to maximum. The upper portion of perimeter slot is operational. The intermediate horizontal slot is operational and bottom slot is restricted. Fume hood air flow is concentrated in the upper portion of enclosure for efficient capture and exhaust of lighter-than-air fumes and hot gases.

The baffle at position **C** provides maximum air flow across the work surface for the collection and removal of fumes generated at the work surface and heavier-than-air gases. In this position, perimeter slot and intermediate slot remain open and operational, top slot is closed.

BAFFLE INSTALLATION AND ADJUSTMENT (cont..)

Installing Multi-Position Fixed Baffle

1. Place top baffle into position by engaging top edge into front exhaust collar extrusion. Lift baffle up and into upper support brackets to lock into position.
2. Place center baffle into desired exhaust position by engaging top edge into appropriate slots on bottom of uppermost baffle support brackets, see positioning label on right-hand side panel. Lift and lock baffle into position.
3. Place lower baffle into proper position. Lift and lock baffle into lower support brackets.

Installing Remote Exterior Control Baffle

1. Place top baffle into position by engaging top edge into front exhaust collar extrusion. Lift baffle up and into upper support brackets to lock into position.
2. Align forked end of remote arm with any of three (3) slots in right-hand upper baffle support bracket. Lift center baffle up and into slots in upper baffle supports, being sure to capture right-hand edge of baffle between fingers of remote control arm. Lift and lock baffle into position.
3. Place lower baffle into proper position. Lift and lock baffle into lower support brackets.

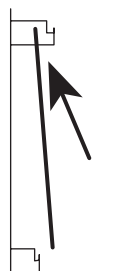
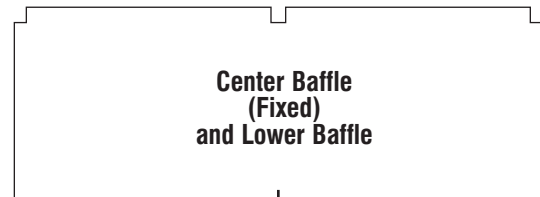
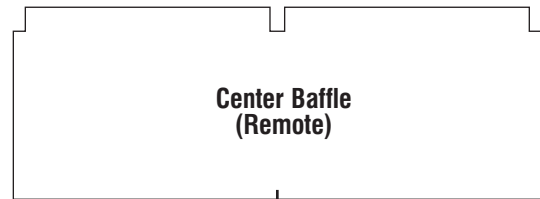
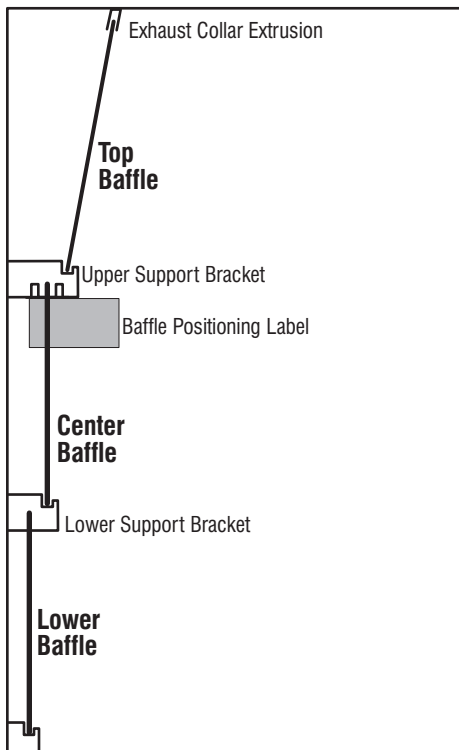

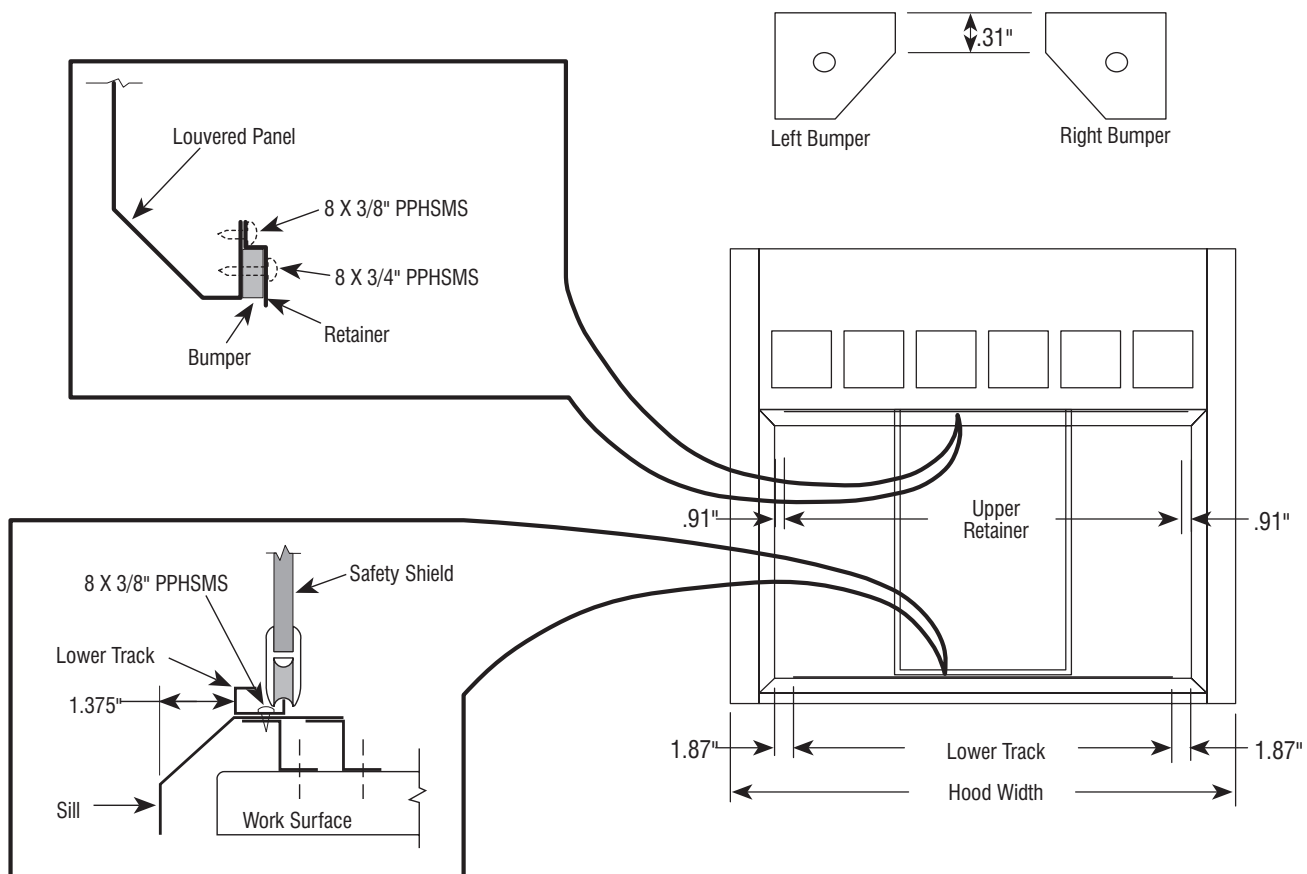
OPERATION, MAINTENANCE AND INSTALLATION INSTRUCTIONS**INSTALLATION****INSTALLING SAFETY SHIELDS IN RESTRICTED BYPASS, CONSTANT VOLUME BYPASS, AND RADIOISOTOPE FUME HOODS**

1. Locate lower track assembly according to dimensions shown.
2. Use lower track assembly as template for locating holes. Drill .128" diameter holes in sill as illustrated, through existing holes in track assembly.
3. Fasten track with No. 8 X 3/8" PPHSMS.
4. Locate upper retainer on rear flange of louvered panel. Locate retainer .91" (29/32") from inside edge of front vertical panel. Drill .128" diameter holes using retainer as template. Fasten with No. 8 X 3/8" PPHSMS.
5. Position and fasten bumpers using No. 8-32 X 3/4" PPHMS, washers and hex nuts.
6. Install safety shield by inserting top into upper retainer channel, then lowering bottom (with rollers) into lower track assembly.

Hood Width	Lower Track	Upper Retainer
48.0"	34.62"	36.56"
60.0"	46.62"	48.56"
72.0"	58.62"	60.56"
96.0"	82.62"	84.56"

INSTALLING SAFETY SHIELDS IN AUXILIARY AIR FUME HOODS

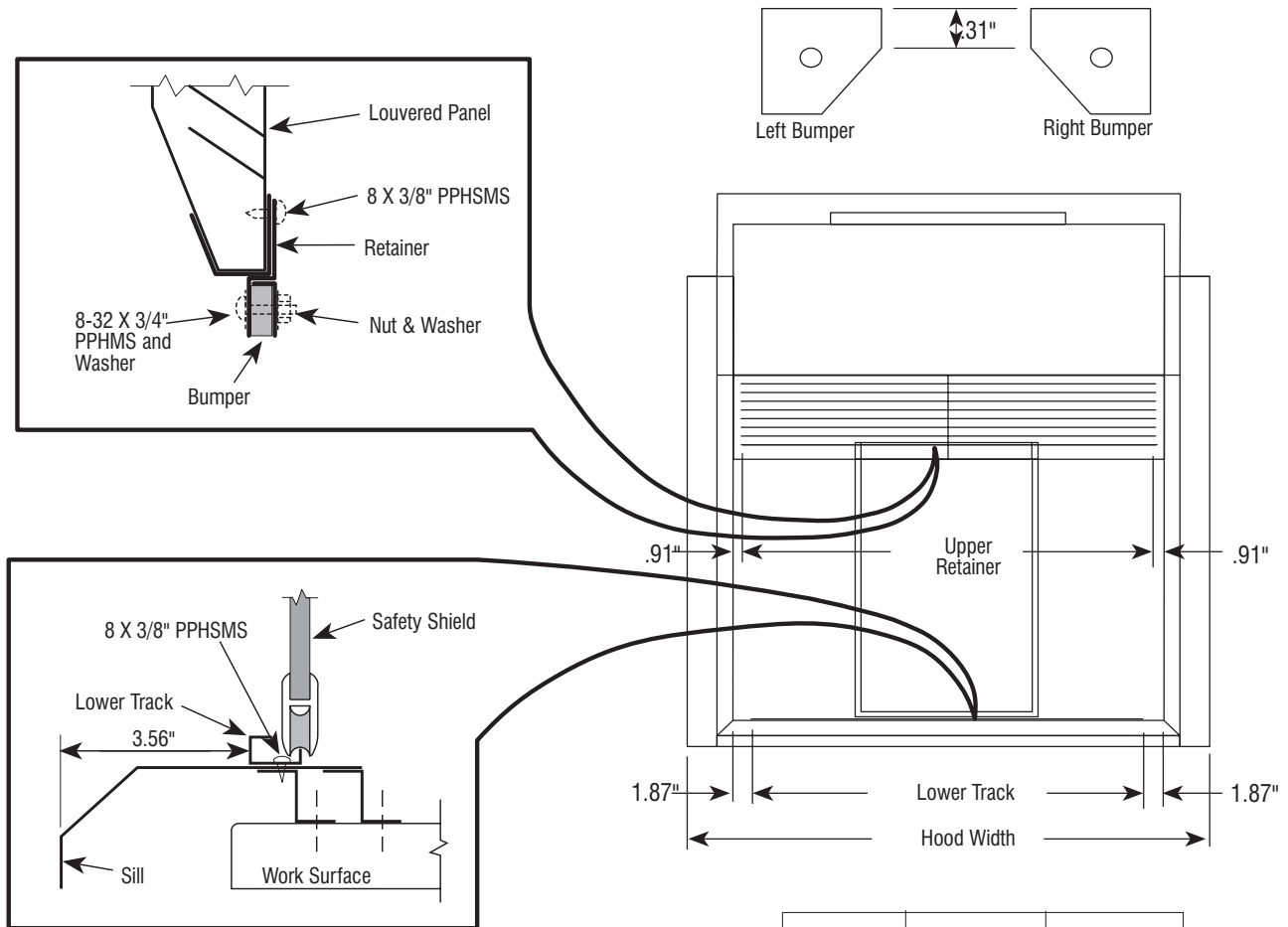

1. Locate lower track assembly according to dimensions shown.
2. Use lower track assembly as template for locating holes. Drill .128" diameter holes in sill as illustrated, through existing holes in track assembly.
3. Fasten track with No. 8 X 3/8" PPHSMS.
4. Locate upper retainer on rear flange of louvered panel. Locate retainer .91" (29/32") from inside edge of front vertical panel. Drill .128" diameter holes using retainer as template. Fasten with No. 8 X 3/8" PPHSMS.
5. Position and fasten bumpers using No. 8-32 X 3/4" PPHMS, washers and hex nuts.
6. Install safety shield by inserting top into upper retainer channel, then lowering bottom (with rollers) into lower track assembly.

Hood Width	Lower Track	Upper Retainer
48.0"	34.62"	36.56"
60.0"	46.62"	48.56"
72.0"	58.62"	60.56"
96.0"	82.62"	84.56"

INSTALLATION**INSTALLING CEILING ENCLOSURE TO FUME HOODS OTHER THAN AUXILIARY AIR AND POSTLESS SASH****Hardware included:**

- 1 - Front panel
- 1 - Front panel-removable
- 2 - Side panels
- 2 - Front support brackets
- 2 - Rear support brackets
- 1 - Bag assembly

Tools required:

- #2 Phillips screwdriver.

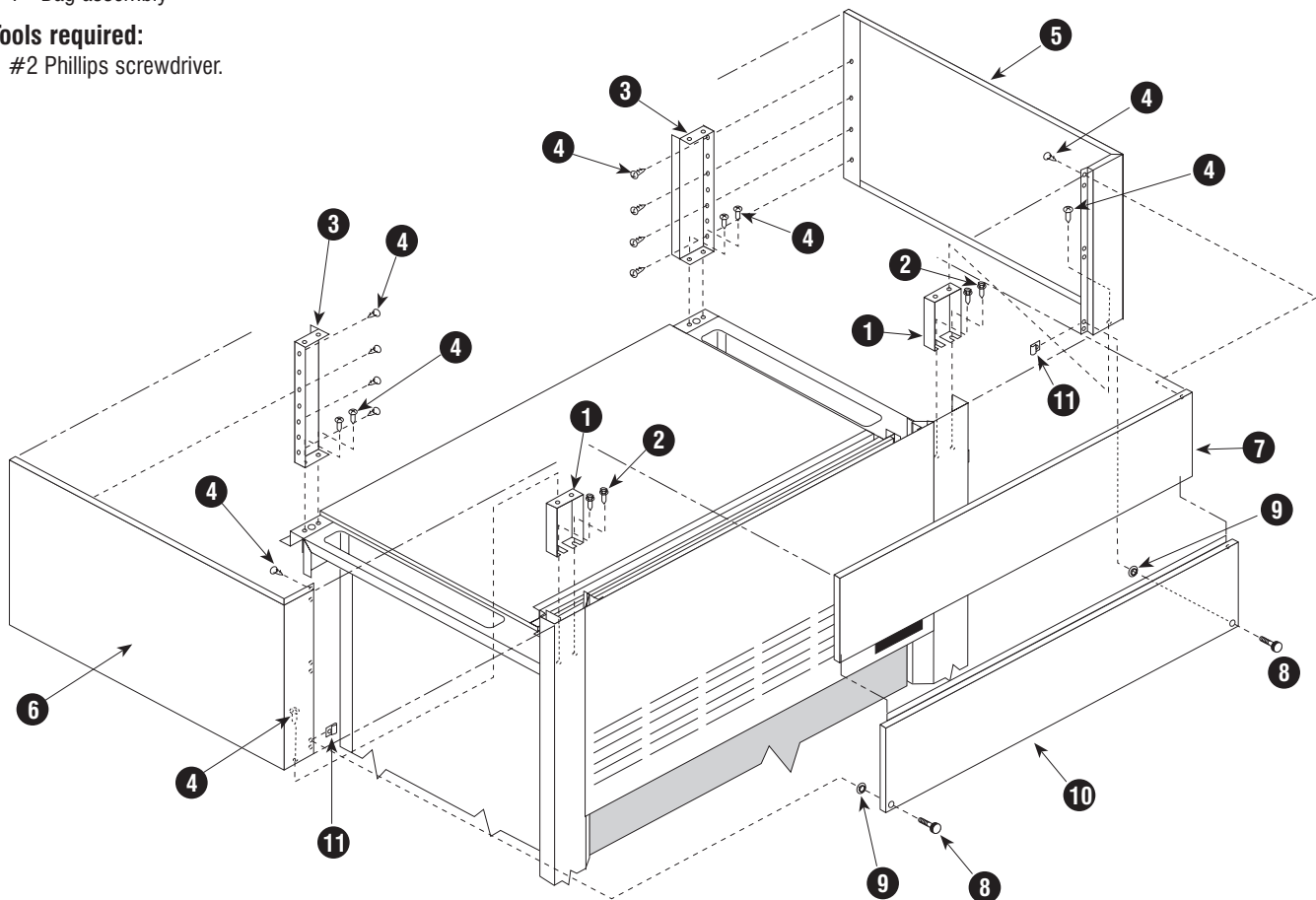

1. Fasten support brackets (1) in front top of frame assembly in holes provided. Use 1/4-20 X 3/4" hex head thread cutting screws (HHTCS) (2) furnished in bag assembly to fasten brackets.
2. Fasten rear support (3) to rear top of frame assembly. Use No. 8 X 5/8" Phillips pan head sheet metal screws (PPHSMS) (4) furnished in bag assembly.
3. Install right-hand (5) and left-hand (6) side panels to supports using No. 8 X 5/8" PPHSMS (4).
4. Install front panel (7) to side panels with No. 8 X 5/8" PPHSMS.
5. Subassemble thumb screws (8) and push retainers (9) to removable panel (10).
6. Insert hole fasteners (11) in larger hole in flange of side panels.
7. Insert top flange of removable panel under and behind front panel. Fasten thumb screws and tighten.

INSTALLING CEILING ENCLOSURE TO AUXILIARY AIR FUME HOODS

Hardware included:

- 1 - Front panel-removable
- 2 - Side panels
- 2 - Front support brackets
- 2 - Rear support brackets
- 1 - Bag assembly

Tools required:

- #2 Phillips screwdriver.

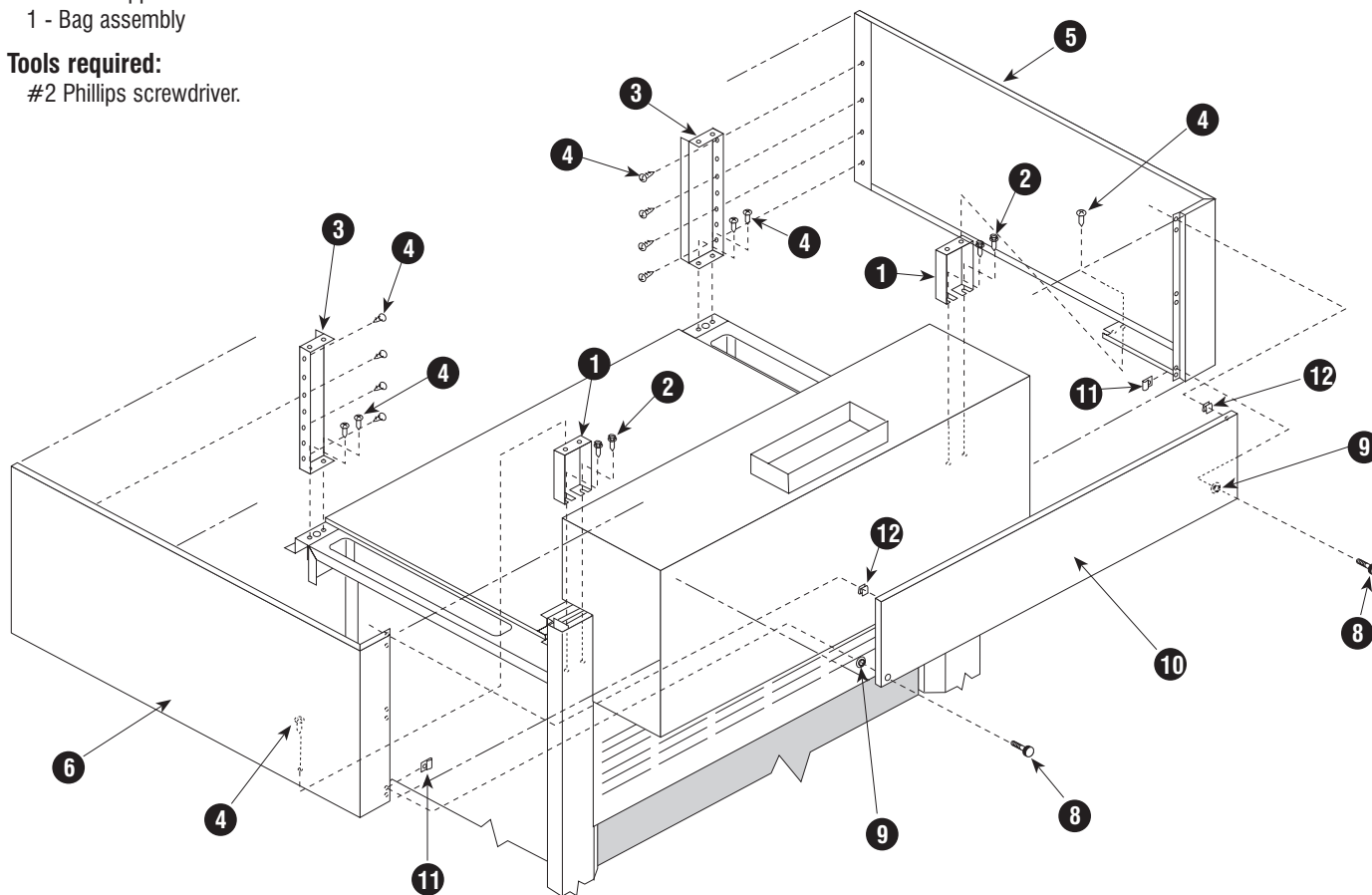

1. Fasten support brackets (1) in front top of frame assembly in holes provided. Use 1/4-20 X 3/4" hex head thread cutting screws (HHTCS) (2) furnished in bag assembly to fasten brackets.
2. Fasten rear support (3) to rear top of frame assembly. Use No. 8 X 5/8" Phillips pan head sheet metal screws (PPHSMS) (4) furnished in bag assembly.
3. Install right-hand (5) and left-hand (6) side panels to supports using No. 8 X 5/8" PPHSMS (4).
4. Install clips (12) into top square holes of removable panel (10).
5. Subassemble thumb screws (8) and push retainers (9) to removable panel (10).
6. Insert hole fasteners (11) in larger hole in flange of side panel.
7. Insert clip of top flange of removable panel into square holes of side panels. Fasten thumb screws and tighten.

INSTALLATION**INSTALLING CEILING ENCLOSURE TO POSTLESS SASH TYPE FUME HOODS****Hardware included:**

- 2 - Front panels
- 2 - Front panels-removable
- 2 - Side panels
- 2 - Front support brackets
- 2 - Rear support brackets
- 2 - Middle support brackets
- 1 - Bag assembly

Tools required:

- #2 Phillips screwdriver.

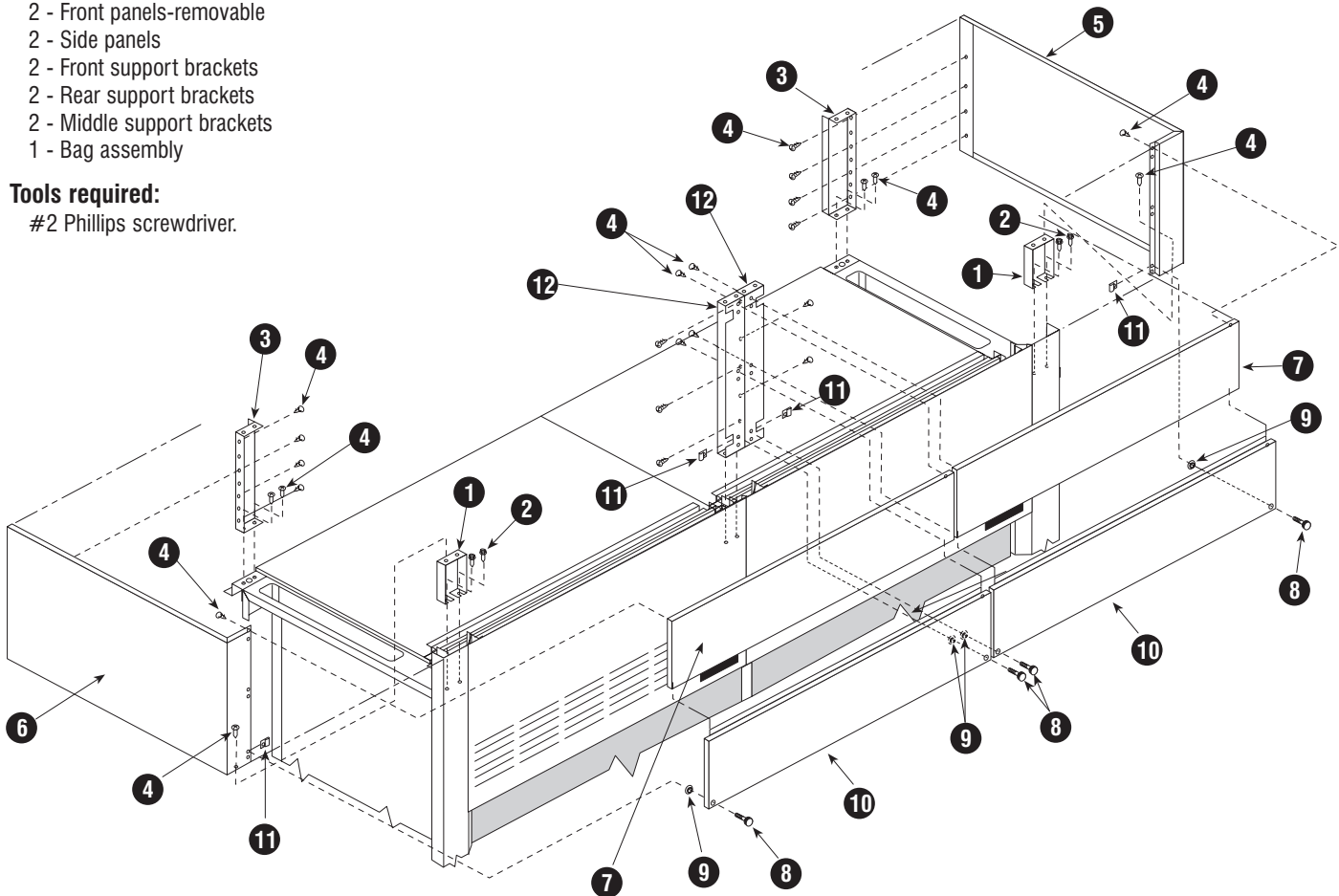

1. Fasten support brackets (1) in front top of frame assembly in holes provided. Use 1/4-20 X 3/4" hex head thread cutting screws (HHTCS) (2) furnished in bag assembly to fasten brackets.
2. Fasten rear support (3) to rear top of frame assembly. Use No. 8 X 5/8" Phillips pan head sheet metal screws (PPHSMS) (4) furnished in bag assembly.
3. Install right-hand (5) and left-hand (6) side panels to supports using No. 8 X 5/8" PPHSMS (4).
4. Install two middle supports (12) to louver panels with four No. 8 X 5/8" PPHSMS (4).
5. Install front panels (7) to side panels and middle supports using No. 8 X 5/8" PPHSMS (4).
6. Subassemble thumb screws (8) and push retainers (9) to removable panels (10).
7. Insert hole fasteners (11) in larger hole in flange of side panels.
8. Insert top flange of removable panels under and behind front panels. Fasten thumb screws and tighten.

INSTALLATION

FUME HOOD MONITOR

Models 54L0335 and 54L0405

Proper fume hood operation is key to laboratory safety, comfort and energy management. OSHA requires that laboratories take measures to ensure proper and adequate operation of fume hoods. Recommendations include the use of a continuous air monitoring device. The ANSI Z9.5 and NFPA 45 standards reinforce these requirements.

Hamilton monitors have the ability to monitor true fume hood face velocity using thermal sensors located in the instrument. The thermal sensors are exposed to clean laboratory air only. They can be surface-mounted in minutes eliminating the need for expensive panel cutouts.

Each model is equipped with indicator lights that illuminate based on a pre-determined set-point. An audible 85dB piezoelectric alarm sounds and a red indicator light illuminates to warn of potentially dangerous low air flow conditions.

- **54L0405**
 - Low flow set point
 - Audible and visual alarm
 - I/O options

- **54L0335**
 - Analog meter
 - Audible and visual alarm
 - I/O control



Hamilton fume hood monitors are shipped with operation manuals.

EXHAUST FILTER INSTALLATION

Product Numbers 54L296, 54L297, 54L298 and 54L299

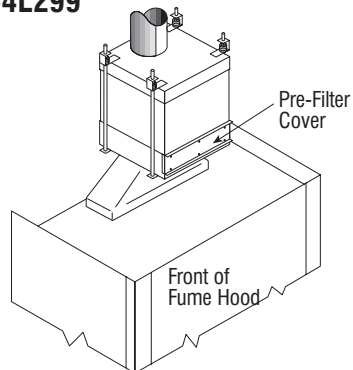

The pre-filter cover faces **forward** on Restricted Bypass and Constant Volume Bypass hoods.

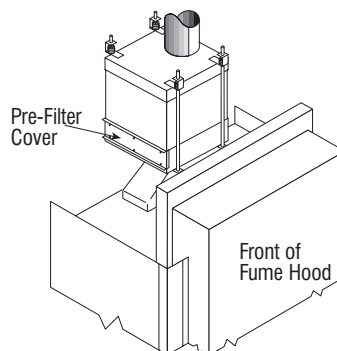

The pre-filter cover faces **to the left** on Auxiliary Air hoods.

Securely attach the filter inlet collar to hood exhaust transition using same method as followed in the duct system. Filter outlet may be attached to duct using flexible connector or same as inlet connection.

INSTALLATION OF MINIHILIC GAUGE

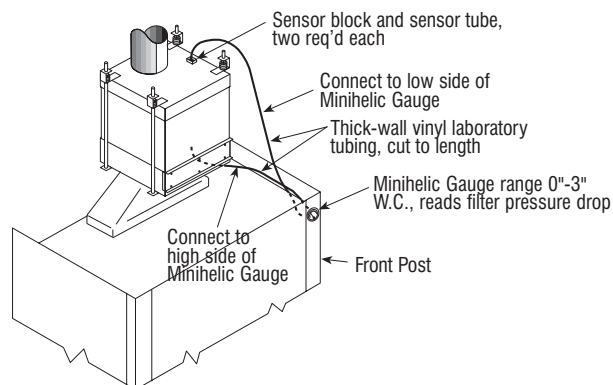

Replacement filter sets consist of one rough and one HEPA filter.

Product Number 54L302 – Filter set for 54L296 or 54L298.

Product Number 54L300 – Filter set for 54L297 or 54L299.

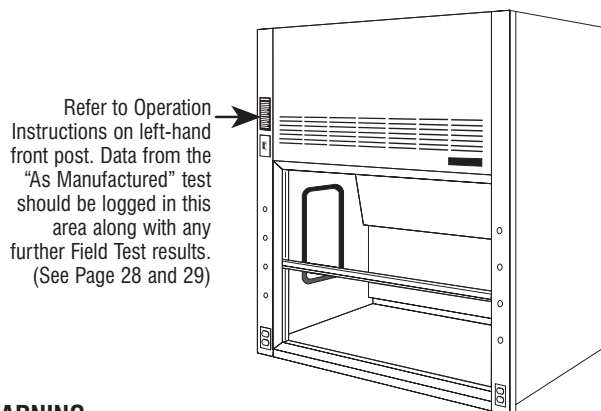
WARNING/OPERATING INSTRUCTIONS**WARNING/OPERATING INSTRUCTIONS****WARNING**

This product is intended for use with certain chemicals that can cause serious injury or illness through inhalation or physical contact. While this product is intended to minimize exposure to certain hazardous chemicals when selected, installed and operated properly, its performance and the safety of the user is affected by a number of factors. These include the HVAC system, the specific chemicals and processes being used, proper operation and the condition of the room.

Before using this fume hood, consult the owner's industrial hygienist or safety representative to make sure: 1) the specific fume hood alarms, controls and the HVAC system have been properly selected and are operating correctly, 2) the hood has been tested after installation and routinely thereafter to ensure the fume hood is providing the proper containment for the specific chemicals and processes being used, 3) there has been appropriate training on the correct use of the fume hood and handling of the specific chemicals and the fume hood operating instructions have been reviewed, 4) any personal protective devices that are required are properly selected and provided, and 5) the fume hood is being operated at the appropriate face velocity. The fume hood should never be operated with the sash in the full open position.

OPERATING INSTRUCTIONS

Failure to follow these instructions could result in physical injury or illness.

Caution: Do not use hood for perchloric acid procedures.

1. Do not use this fume hood unless you have received proper training from the owner's industrial hygienist or safety representative.
2. This fume hood is not intended to be used with all chemicals or all chemical processes. Consult the owner's industrial hygienist or safety representative to determine whether the hood is appropriate for the chemicals and processes to be used.

3. Verify that the fume hood exhaust system and controls are operating properly and providing the necessary air flow. If in doubt, the owner's industrial hygienist or safety representative should be consulted. It is recommended that the hood be equipped with an air flow monitoring device. Before using the fume hood, verify that the monitor is operating properly by testing the monitor.
4. The hood should not be operated with the sash in the full open (set-up) position. When the hood is in use, the opening of the sash glass should be kept at a minimum. On a vertical rising sash, the sash glass should be no higher than 18". Horizontal sliding panels on combination sashes must be closed when sash is raised vertically. The sash should remain closed when the hood is not in use.
5. Place chemicals and other work materials at least six (6) inches inside the sash.
6. Do not restrict air flow inside the hood. Do not put large items in front of the baffles. Large apparatus should be elevated on blocks. Remove all materials not needed for the immediate work. The hood must not be used for storage purposes.
7. Never place your head inside the hood.
8. External air movement can affect the performance of the hood. Do not operate near open doors, open windows or fans. Avoid rapid body movements. Do not open the hood if there are cross-drafts or turbulence in front of the hood. Do not open the sash rapidly.
9. If this hood is equipped with adjustable baffles, do not adjust the baffles without consulting the owner's industrial hygienist or safety representative.
10. Wear gloves and other protective clothing if contact with contaminants is a hazard.
11. Clean spills immediately.
12. If fumes or odors are present, stop operating the hood, close the sash and contact the owner's industrial hygienist or safety representative immediately.
13. It is recommended that this fume hood be tested and certified annually by the owner according to applicable industry and government standards.

MAINTENANCE & ADJUSTMENTS

GENERAL MAINTENANCE OF FUME HOODS

Fume hood maintenance procedures consist primarily of clean-up, adjustment, lubrication, and replacement of worn, damaged or non-functioning parts. Lubrication of sash guides, cables, pulley wheels, and other working parts should be accomplished as required and replacement of broken, worn, or non-functioning parts as needed. The following items should be **inspected and serviced at least semi-annually**:

- Liner and baffles for condition and cleanliness.
- Low air flow detectors.
- Service fixtures and lights.
- Pulleys and belts.
- Sash operation and counterbalance cables including a complete visual check of the entire system.
- Make sure there is a 1/16" clearance between cable keepers and pulley sheaves.
- Velocity and pressure sensing detectors.
- Low or no flow alarms, both visible (lights) and audible (horns or bells).
- Signal transmission for alarms designed to activate signals at more than one location.
- Instrument verification of fume hood face velocity and determination of usage by observation and interview.
- Ductwork and blower.

WARNING

Use only fluorocarbon grease on blower since any other type is to be considered potentially dangerous.

WARNING

Frayed or broken cables should be replaced to avoid personal injury or damage to fume hood. Not all cable manufacturer's cables are the same quality and cycle life.

Clean-up should be accomplished by, or under the supervision of, a knowledgeable technician and should include removal of all baffles for clean-up of all interior surfaces.

Flush all spills immediately using neutralizing compounds as required and clean thoroughly. Use good housekeeping in laboratory fume hoods at all times.

FUME HOOD INSPECTION PROCEDURES

Safety considerations require that a schedule of inspection and documentation be set up for every laboratory fume hood at least annually.

An inspection record should be maintained. This record may be in the form of a label attached to the fume hood, or a log held by the laboratory director or health safety director.

Inspection procedures should include instrument verification of fume hood face velocity and a determination of usage by

observation and interview. These procedures should also consist of a physical examination of liner condition and cleanliness, baffle and sash operation and condition, counterbalance cables, light operation and condition, and service fixture function.

Inspection results should be recorded and reported to the proper authority for any required action.

NOTE: Special purpose fume hoods such as those used with radioactive materials or perchloric acid require additional inspection procedures to cover special equipment and requirements.

Options, such as low air flow detectors, when installed, should be inspected at least annually. Where extreme hazardous or corrosive conditions exist or when filters are present in the system, the inspection frequency should be increased appropriately. Velocity and pressure sensing detectors should be tested at each inspection. Low-flow or no-flow alarms of the visible (lights) or audible (horns or bells) type should be tested for correct operation at least at each inspection. Signal transmission for alarms designed to activate signals at more than one location should be verified at each location during each inspection. Frayed or broken belts should be replaced promptly.

FLUORESCENT LIGHT TUBE REPLACEMENT – BENCH TOP, HI-LINE AND FLOOR-MOUNTED HOODS

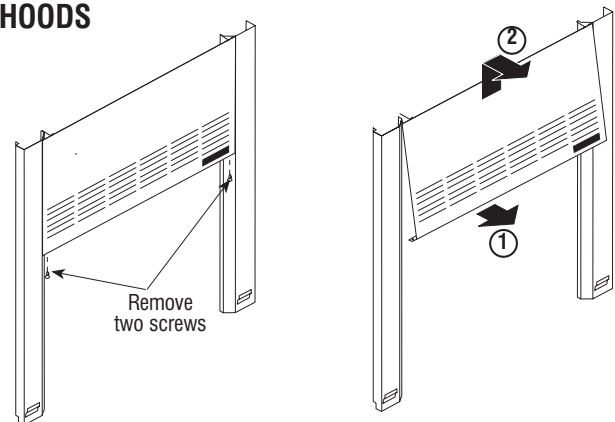

1. Remove sash enclosure if applicable.
2. Remove two (2) screws securing bottom of louver panel to front posts. Pull louver panel up to disengage from studs and remove panel.
3. Squeeze bottom edge of lamp housing to disengage from galvanized channel. Rotate lamp housing up to expose bulbs. Replace bulbs with same type as in unit. Turn on light switch to verify connections.
4. Reverse Steps 1–3 to return hood to usable condition.

MAINTENANCE & ADJUSTMENTS

FLUORESCENT LIGHT TUBE REPLACEMENT – AUXILIARY AIR FUME HOODS

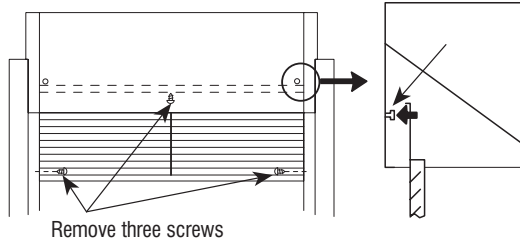

1. Remove louver panel assembly by removing three (3) screws, as shown above.

NOTE: Two people should perform this operation, one to hold the louver panel, and the other to remove the three screws.

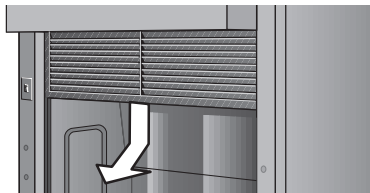

2. With one person at each end, lift the panel up and push top inward to disengage from two (2) retaining studs, then lower the panel and tilt the bottom outward to remove as shown above.
3. Lift sash enclosure up one (1) inch and lay back over top of light housing. Grasp and rotate fluorescent tube to remove. Replace with new tube and re-assemble in reverse order.

FUME HOOD SERVICE FIXTURES

Removal of Gasketed Access Panel

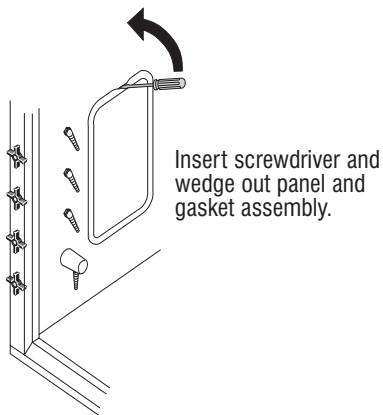

Installation of Gasketed Access Panel

Twist the corners of gasket towards cutout before insertion. Replace the panel and work the entire periphery of the gasket to be sure that the gasket is completely snapped into position. Gasket should be smooth and tight when properly seated.

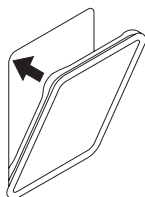

The fixtures used within fume hoods are needle valve type. It is necessary to remove the handle from the valve and then remove the valve mechanism. This can be done through the access panels (shown above) if fixtures are mounted in the superstructure, or from inside the cupboard if the fixtures are deck mounted.

Access to the valves by removal of the exterior end panels (Step 1 on Page 4) permits seat replacement without the need to remove the valve. This approach is recommended when ends are exposed and accessible.

Access to service fixture valves on fume hoods without access panels is obtained by removal of the exterior end panels (Step 1 on Page 4) when hoods are free-standing.

Access Through Front Posts

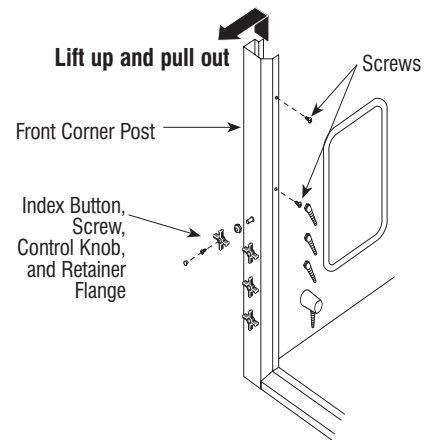

When ends are not accessible, access is gained through the front posts. Remove louver panel, unscrew index button, control knob, and retainer flange from fixture handle rod. Remove two (2) screws from post as shown above, lift up and outward to remove post. Electrical fixtures are connected to post with flexible conduit and can remain attached.

CLEANING FUME HOOD INTERIORS

Fume hood liners are maintained by an occasional washdown with detergent and warm water. Stains and salt deposits can be removed with a weak acid solution (5%) or an appropriate solvent – **DO NOT USE ACETONE**. Remove baffles for access to all surfaces. See Page 13 for removal and installation procedures. For deposits of dirt or stubborn stains on stainless steel, follow procedures outlined under Working Surface Section.

The use of organic chemicals or materials in a specialized perchloric acid fume hood with a stainless steel interior should be avoided.

MAINTENANCE & ADJUSTMENTS

FRAME GLASS AND CABLE REPLACEMENT

NOTE: Special parts, options, and accessories should be maintained as required.

Sashes occasionally require service. The glass may fog due to the condensation of chemical vapors, and such materials should be removed promptly by washing with water and detergent to prevent etching of the glass.

WARNING

If cable is frayed or damaged, it MUST be replaced to avoid personal injury or damage to the fume hood

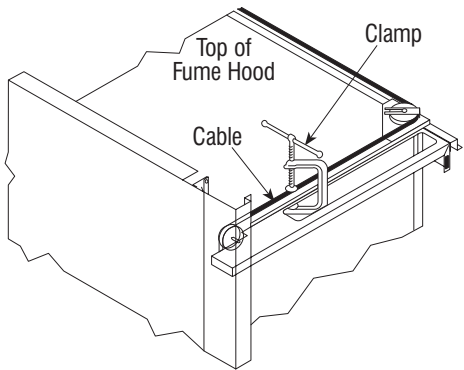

1. Hold the sash in the closed/down position by clamping the sash counterbalance cable to the top structural frame member. In some situations, access to the top of the fume hood may be gained by:
 - Removing end panel if end of hood is clear - See Page 4.
 - Removing front louver panel - See Page 21 and 22.
 - Removing blower enclosure panels- See Page 16–18.

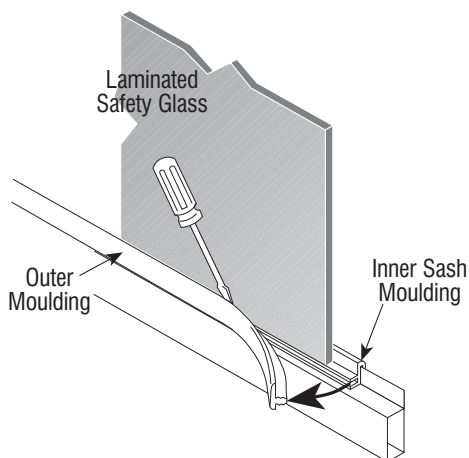

2. Remove the outer portion of the sash moulding strip on all four sides of the frame. Use a flat blade screwdriver to pry

away from inner portion of moulding. Dispose of broken and both portions of the sash moulding strip.

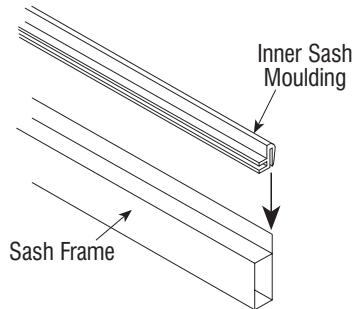

3. Press the four (4) sections of the inner sash moulding strip over the sash frame edge.

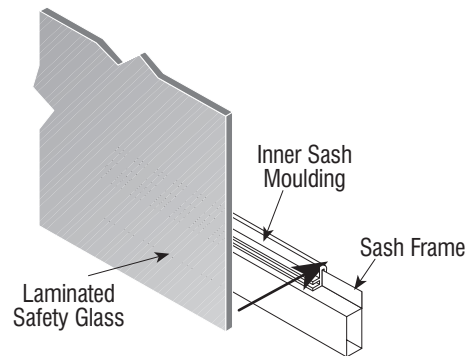

4. Place the new sash glass onto the inner sash moulding and hold in place.

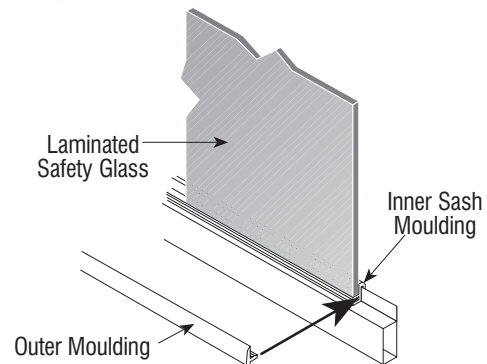

5. Press the outer moulding strip into the groove of the inner strip.
6. Remove clamps holding the sash cable in place and test for balance.
7. Sash counterbalance cable is replaced by removing front corner post (See Page 22) for access. Field repairs can be made on existing cable if the problem is an end fastening device or disconnection. If cable is frayed or broken, order replacement cable – describe hood type, size and cable length.

MAINTENANCE & ADJUSTMENTS

SASH GLASS REPLACEMENT – RESTRICTED BYPASS AND CONSTANT VOLUME BENCH TOP FUME HOODS THAT HAVE BEEN INSTALLED

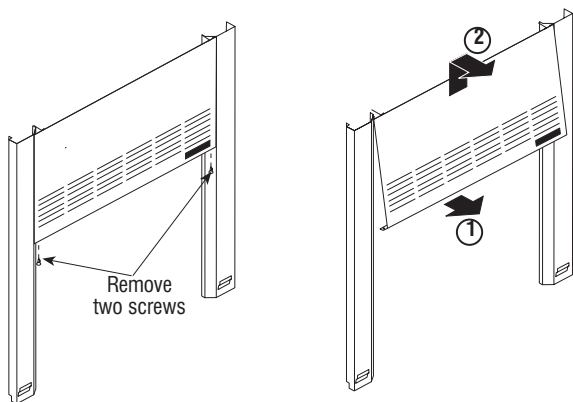
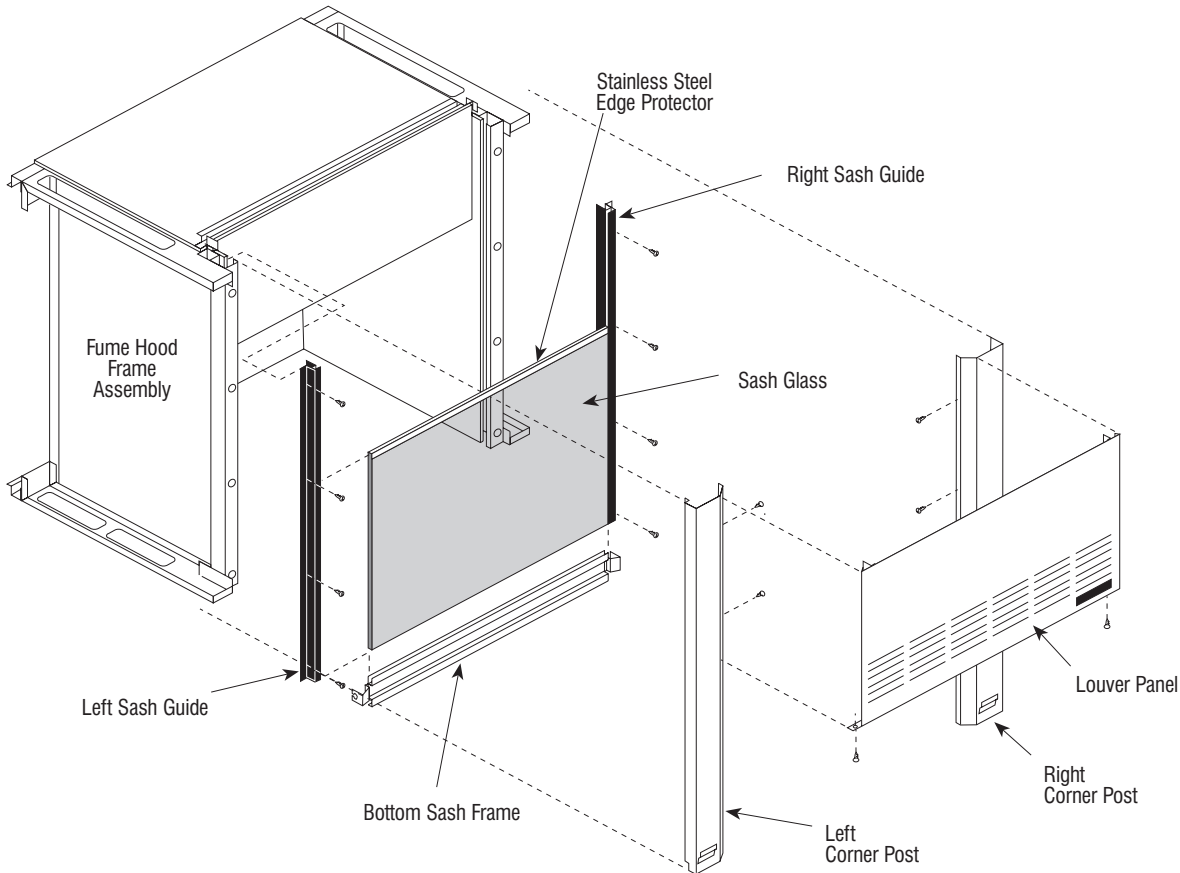

1. Remove louver panel by removing one screw in lower corner at each end.
2. Pull bottom out and lift entire panel up to remove.

3. Remove both front corner posts, See Page 22.

WARNING

If cable is frayed or damaged, it MUST be replaced to avoid personal injury or damage to the fume hood

4. After removal of one of the corner posts, clamp the sash cable to the top of the side frame assembly. See page 23.
5. Remove screws that hold the sash guide to the front frame upright and slide the guide up and away from the sash. **Care should be taken when the sash guide is removed so that the glass does not fall from the remaining guide.**

MAINTENANCE & ADJUSTMENTS

SASH GLASS REPLACEMENT – RESTRICTED BYPASS AND CONSTANT VOLUME BENCH TOP FUME HOODS THAT HAVE BEEN INSTALLED (Cont..)

6. While holding the sash glass, first remove the upper stainless steel edge protector. Then force the glass from the bottom sash pull by pulling upward while holding the sash pull in place. At this point the glass and gasket material should come loose, the bottom sash frame remains attach to the sash cables and one sash guide.
7. Place gasket material on the bottom of the new sash glass. Align with the bottom frame member and press into place. Replace the stainless steel edge protector on the top horizontal edge of the glass. Replace the sash guide and remove clamps holding the sash cables. Move the sash up and down to test for proper alignment in the sash guides. If at this point you notice the glass is not completely seated into the bottom frame member, tap gently on the bottom with a rubber mallet to seat the glass.
8. Replace the front corner posts and the louver panel.

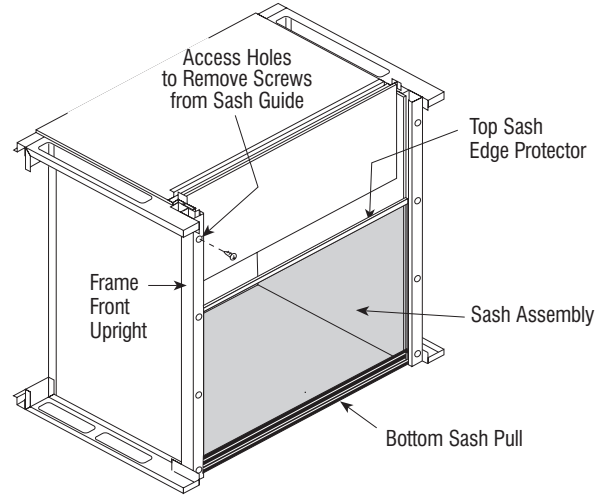

SASH GLASS REPLACEMENT – AUXILIARY AIR BENCH TOP FUME HOODS THAT HAVE BEEN INSTALLED

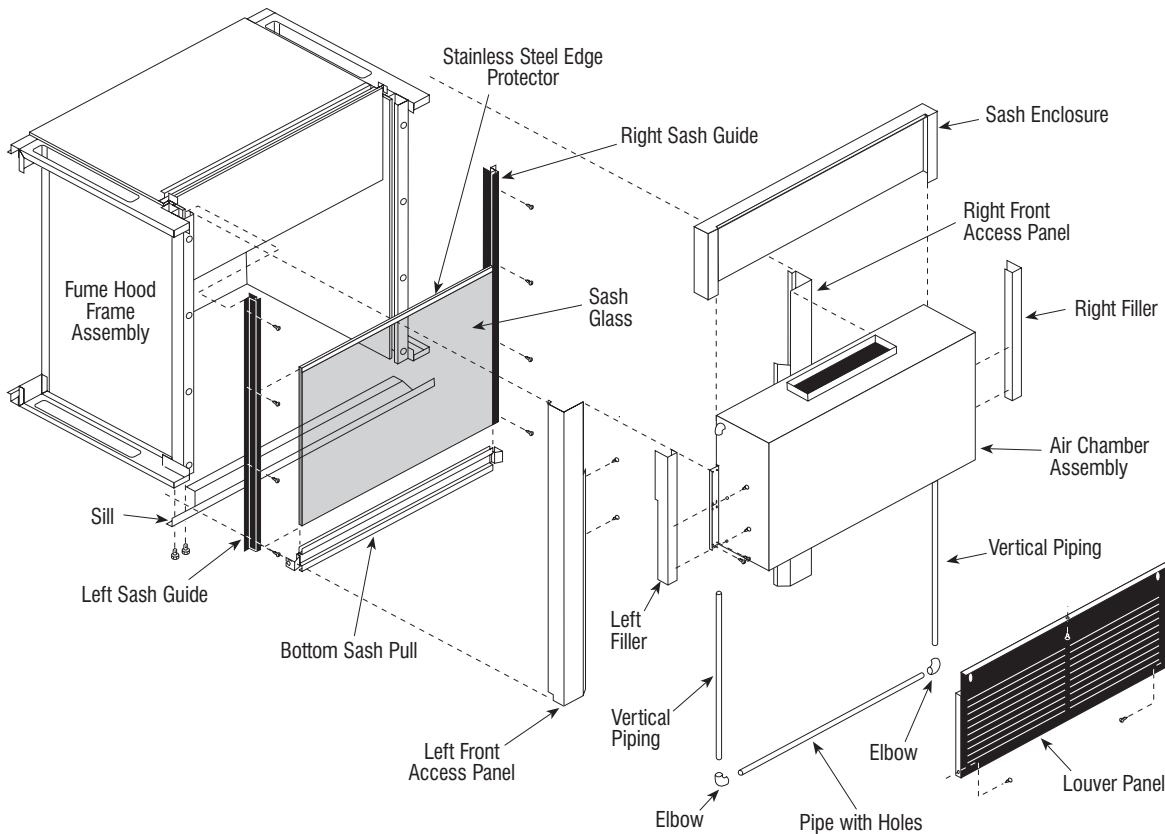

1. Follow Steps 1–8 from Page 24 and top of this page.

MAINTENANCE & ADJUSTMENTS**SERVICING SUPPLY CHAMBER AIR FILTER –
AUXILIARY AIR FUME HOODS**

The supply chamber air filter is located in the supply air chamber. The change out of the filter requires the removal of the louver panel. It is the panel consisting of all louvers for bypass air to enter when the sash is closed. Refer to Page 21 and 22 for instructions on how to remove the louver panel.

1. Remove the perforated grille that covers the bottom of the chamber. Remove a series of sheet metal screws that secures the front of the grille in place, tilt this edge down and pull out to release the grille from the angle at the rear of the chamber.

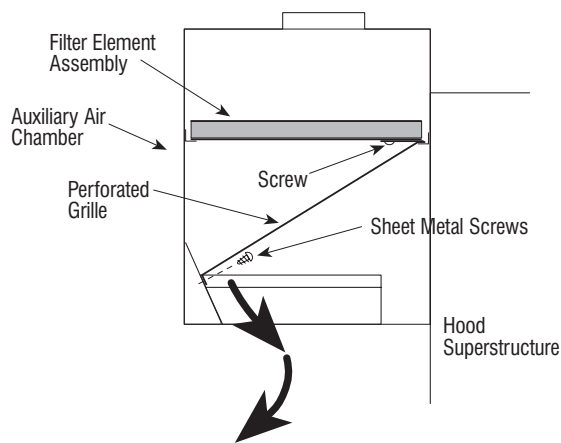

2. The removal of the perforated grille provides access to the metal enclosure that sandwiches the filter material. This metal enclosure is trapped at the back by two short flanges and rests on top of an angle mounted at the front of the chamber. To allow the front of the metal enclosure to drop down, turn the two screws found on the sandwiched enclosure one-half turn, this releases a metal plate that overlaps the angle on the front of the chamber.
3. With the removal of the enclosure and separation of the top and bottom perforated panels, the filter material can be cleaned or replaced. The various stages found inside the supply chamber provides a slow release of air and an even distribution.
4. Be careful to re-install the pieces in the chamber in the same manner as removing them. This is to ensure a functional supply air fume hood.

EXHAUST FILTER REPLACEMENT**WARNING**

Wear adequate protective devices and use techniques to prevent contamination of the laboratory environment. Filter exchange should be accomplished by knowledgeable personnel who perform sterilization procedures or are trained for the safe handling of radioactive materials. Some users prefer to wet the filter media with a steam or aerosol generator to increase adhesion of particles.

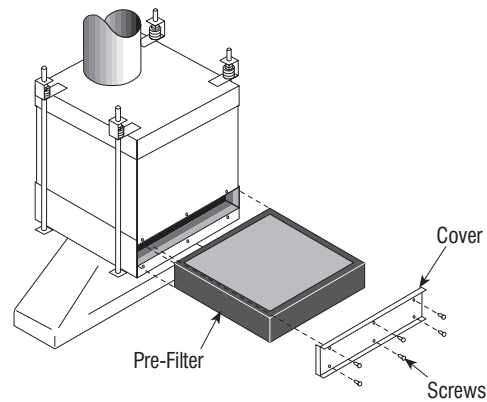

To remove pre-filter – remove six (6) screws that secure the pre-filter cover. Slide the filter out. Slide new filter into the housing and secure cover in place.

To remove final filter – loosen the nuts above the springs to unclamp the filter. Continue turning the nuts until they contact the upper flange of the spring bracket and lifts the plenum away from the filter approximately 1/8 inch.

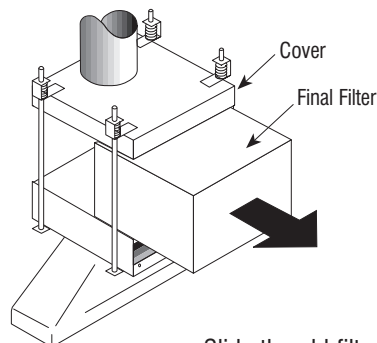
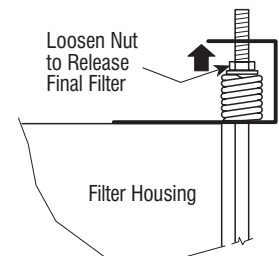

Slide the old filter out (the rods will support the upper plenum and duct work). Insert the new final filter. Turn the four (4) nuts down to compress the springs. Inspect seal after installation and periodically thereafter.

MAINTENANCE & ADJUSTMENTS

BLOWER RPM ADJUSTMENTS

1. Remove housing over motor blower assembly.
2. Loosen the four (4) bolts [A] which hold the motor mounting plate stationary so that the plate has a vertical movement, as shown in illustration below. This should be done so that a later adjustment for correcting belt tension can be made.
3. Make all adjustments **ONLY** with the outside half sheave [B] on the driving shaft.
4. To increase the RPM of the blower, increase the diameter of the driving sheave by loosening the Allen screw [C] and turning the outside half-sheave toward the motor. Tightening the Allen screw to the flat portion of the threaded shaft then fixes the diameter of the sheave.
5. To decrease the RPM of the blower, decrease the diameter of the driving sheave by loosening the Allen screw [C] and turning the outside half-sheave away from the motor. Tightening the Allen screw to the flat portion of the threaded shaft then fixes the diameter of the sheave.
6. Correct belt tension (side play 1/2" to 3/4") can now be set by adjusting the loosened motor mounting plate and tightening the four (4) bolts.

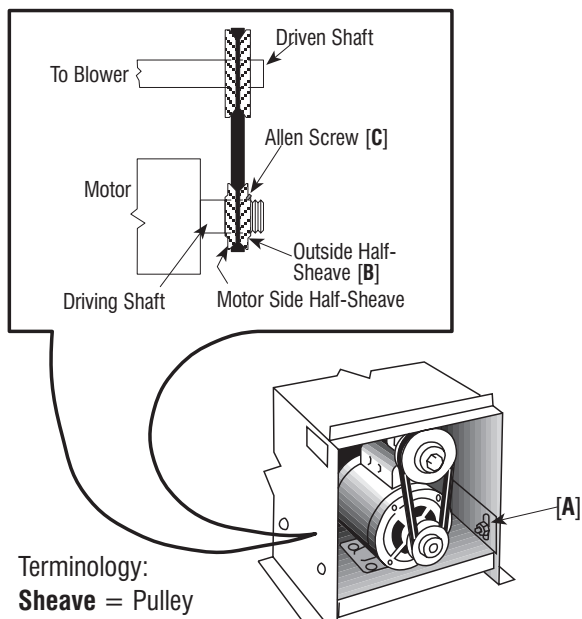

Driven = Attached to blower shaft
Driving = Attached to motor shaft

MONITORING EXHAUST FILTERS USING A MANOMETER ASSEMBLY

When a filter device is installed on a fume hood exhaust system, it is important that the filter performance and condition be monitored to ensure proper performance of the filter and of the fume hood to which it is connected.

By measuring the pressure drop across the filters, the manometer assembly will provide information on filter function and condition.

Manometer reading with clean filters should be recorded and marked with grease pencil on the face of the unit. When the reading changes by one inch, replace filter(s). A maintenance schedule should be set up for periodic reading of the manometer. Frequency can be determined by usage.

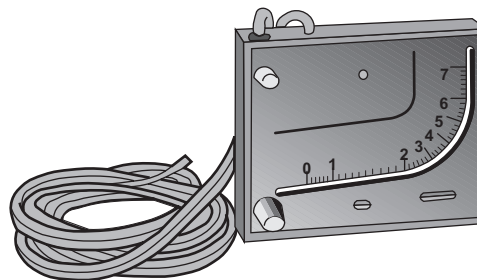

Any change in manometer reading should be investigated. It may indicate filter damage, over-pressure, or an unsafe operating condition. If it is subjected to an over-pressure, disassemble and examine for fluid in loops and tubes. Drain and re-install per instructions.

The manometer assembly requires a periodic cleaning of the exterior with water or naphtha and inspection and adjustment of the oil level. Adjust micrometer knob for zero reading as required. Add .826 sp. gr. red gauge oil when needed, to maintain zero reading.

Proper use of the manometer assembly provides a continuous indication of filter and operation conditions.

NOTE – Be sure to remove manometer when changing filters.

FIELD TESTING**FUME HOOD EVALUATION IN THE FIELD**

It is recommended that the user make provisions to have the following tests performed on all laboratory fume hoods. These tests should be performed by qualified personnel to verify proper operation of the fume hoods before they are put to use. The tests of the fume hoods should be performed after the installation is complete, the building ventilation system has been balanced, and all connections made. Any unsafe conditions disclosed by these tests should be corrected before using the hood.

TEST PROCEDURES**Test Conditions**

Verify that building make-up air system is in operation, the doors and windows are in normal operating position, and that all other hoods and exhaust devices are operating at designed conditions.

Room Conditions

Check room condition in front of the fume hood using a thermal anemometer and a smoke source to verify that the velocity of cross drafts does not exceed 20% of the specified average fume hood face velocity. Any cross drafts that exceed these values shall be eliminated before proceeding with the fume hood test.

Equipment List

- (a) A properly calibrated hot-wire thermal anemometer similar or equal to Anor Model No. 8500.
- (b) A supply of 1/2 minute smoke bombs.
- (c) A bottle of titanium tetrachloride and a supply of cotton swabs or other recognized device for producing smoke.

CAUTION

Titanium tetrachloride fumes are toxic and corrosive. Use sparingly, avoid inhalation and exposure to body, clothing and equipment.

NOTE: It must be recognized that no fume hood can operate properly if excessive cross drafts are present.

Face Velocity

Determine specified average face velocity for the fume hood being tested. Perform the following tests to determine if fume hood face velocities conform to specifications. With the sash in normal operating position, turn ON the exhaust blower. The face velocity shall be determined by averaging the velocity of six readings taken at the fume hood face. Readings shall be taken at the centers of a grid made up of three sections of equal area across the top half of the fume hood face and three sections of equal area across the bottom half of the fume hood face.

NOTE: If not in accordance with specified face velocity, refer to Troubleshooting section on Page 31, for aid in determining the cause of variation in air flow. If face velocity can not be corrected to that which is specified, reclassify fume hood to conform to actual face velocity. Shut off auxiliary air when testing an Auxiliary Air fume hood.

Sash Operation

Check operation of the sash by moving it through its full travel. Sash operation shall be smooth and easy. Vertical rising sashes shall hold at any height without creeping up or down.

AIR FLOW**Fume Hoods**

Turn fume hood exhaust blower on. With sash in the open position, check air flow into the fume hood using a cotton swab dipped in titanium tetrachloride or other smoke source. A complete traverse of the fume hood face should verify that air flow is into the fume hood over the entire face area. A reverse flow of air indicates unsafe fume hood operation. Consult the Troubleshooting section on Page 31, for possible causes and take corrective action. Move a lighted smoke bomb throughout the fume hood work area directing smoke across the work surface and against the side walls and baffle. Smoke should be contained within the fume hood and be rapidly exhausted.

Low Air Flow Monitor

On fume hoods with low flow warning devices, verify that monitor functions properly and indicates unsafe conditions.

FUME HOOD TESTING ANSI/ASHRAE 110-1995

The performance of a laboratory fume hood in providing protection for the worker at the face of the hood is strongly influenced by the laboratory room ventilation, and by other features of the laboratory in which it is installed. Therefore, there arises a need for a performance test which can be used to establish an “as manufactured” and an “as used” performance rating, including the influences of the laboratory arrangement and its ventilating system.

The test presumes a conditioned environment. No test can be devised which would, conducted once or infrequently, (viz., annually), reflect the results which would be obtained in a non-conditioned laboratory with various conditions of windows, wind velocity, etc.

This procedure is a performance test method.

It remains for the user, the hygienist, or the applications engineer to specify what level of hood performance is desired or required. It should be noted that the performance test does not give a direct correlation between testing with a tracer gas and operator exposures. Many factors, such as the physical properties of the material, the rate and mode of evolution, the amount of time the worker spends at the face of the hood, and several other factors must be integrated, by a trained observer, into a complete evaluation of worker exposure. The performance test does, however, give a relative and quantitative determination of the efficiency of hood capture under a set of strict, although arbitrary, conditions. The same test can be used to evaluate hoods in the manufacturer’s facilities under (presumably) ideal conditions, or under some specified condition of room air supply.

The test may be used as part of a specification once the appropriate release rate and required control level are determined. If so used, an “AM” (as manufactured) specification places a responsibility on the hood manufacturer, and an “AU” (as used) specification places responsibilities on others, viz., the designer of the room air supply, the designer of the room layout, etc.

The test sheet attached to the hood reflects hood performance parameters. This sheet represents “AM” testing.

Hamilton recommends that the ASHRAE 110-1995 test procedure be subjected to this hood under “AU” (as used) conditions.

Refer to the ASHRAE Standard 110-1995.

If the above test cannot be performed at the job site, use the SEFA-1.2 1996 test procedure as minimal proof of proper hood performance.

This test consists of a face velocity grid test and a smoke test procedure.

Information and copies of this procedure are available from Hamilton Laboratory Solutions.

Hamilton recommends at least semi-annual verification that this above criteria is subjected to and met by all hoods at your particular facility.

OPERATION, MAINTENANCE AND INSTALLATION INSTRUCTIONS

FUME HOOD TESTING

FIELD EVALUATION OF LABORATORY FUME HOODS

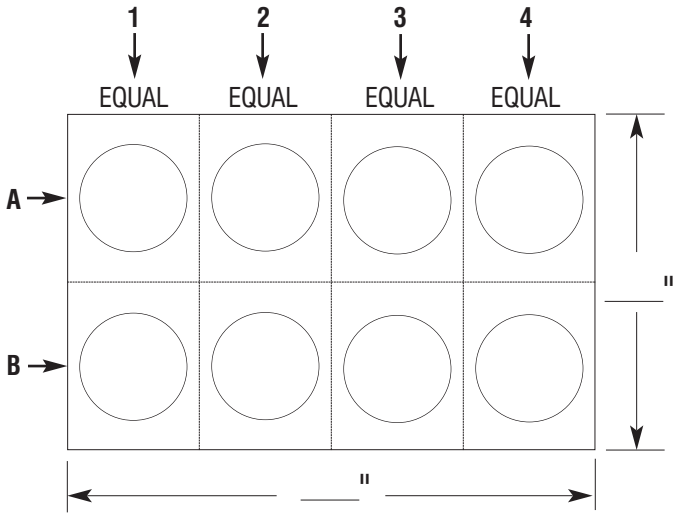

Project Name _____

Location _____

Order Number _____

Room _____ Item _____

Fume Hood Identification _____

Sash Operation _____

Light Operation _____

Baffle Operation _____

Services: A G V W NIT. STEAM

OTHER _____

Conclusion & Comments _____

ALARM CONDITION: FUNCTIONAL _____

 NON-FUNCTIONAL _____

SMOKE TEST: POSITIVE _____

 NEGATIVE _____

Face Velocity Test

Square footage of hood opening _____

... and Bypass ... if any _____

TOTAL _____

1A _____ F.P.M.

1B _____ F.P.M.

2A _____ F.P.M.

2B _____ F.P.M.

3A _____ F.P.M.

3B _____ F.P.M.

4A _____ F.P.M.

4B _____ F.P.M.

TOTAL _____ = _____ avg.

TOTAL C.F.M. = (Avg. X Sq. Ft. of open sash & any bypass)

I certify that the above results were obtained on _____ by _____

Evaluation procedures conducted by _____
 Name Title

TROUBLESHOOTING

When fume hood test procedures detect an improper function, the cause is normally due to insufficient quantity or air flowing through the hood, or due to room cross drafts blowing into or across the face of the fume hood, or a combination of both. The following suggestions are offered to help pinpoint and correct the problem.

Room Cross Drafts

Air moving through an open door located adjacent to the fume hood can cause cross drafts.

An open window or a room air supply located to one side or across from the fume hood can cause disturbing cross drafts.

High-velocity air from ceiling-mounted diffusers can cause a flow of air down and into the top half of the fume hood face that can cause reverse flows of air out of the bottom half of the face.

Insufficient Air Flow

Insufficient air flow through the fume hood can be caused by one or more of the following conditions. Each condition should be checked, and eliminated if possible, to determine which one or combination of conditions may exist.

One possible explanation for low face velocity readings is inaccurate face velocity readings. Check air flow velocity meter type. Was the recommended model used? When was it calibrated last?

If the recommended model was not used, check to make sure the instrument is recommended for low air velocities in the 50 to 100 feet-per-minute range.

If possible, verify readings with another air velocity meter or by checking air volume using a pitot tube traverse of exhaust duct.

Check List

- Who stated that the unit did not operate properly? Position? Title? Employed by?
- What tests were performed? Instruments used? When calibrated? Results?
- Fume hood type and model number? Size?
- Is hood location correct/acceptable? Cross currents present? Traffic past hood?
- Is adequate free or make-up air available? Always? What is supply source? Can it be altered or cut off?
- Did hood ever function properly? Have authorized modifications been made? Is baffle properly installed? Adjusted?
- Have hoods ever been set? Calibrated? Tested? Balanced? By whom?
- Have recent changes been made in heating/cooling system? Describe.

DO NOT DISCARD IMPORTANT TEST AND CALIBRATION DATA ENCLOSED!

TO BE REMOVED ONLY BY HOOD USER

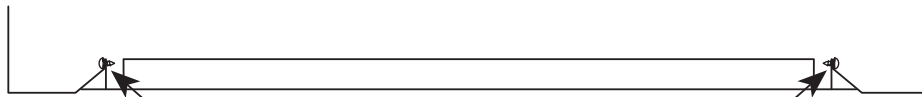

REMOVE SHIPPING SCREWS FROM TOP OF
LOUVER PANEL AFTER PLACING HOOD IN
POSITION ON WORK SURFACE