

**Tools Required:**

Power Drill  
Phillips Head Screwdriver

**Hardware Included:**

- 1 – Ceiling Collar Assembly
- 1 – Cover Mounting Channel
- 1 – Removable Cover Assembly
- 1 – Right Mounting Channel Assembly
- 1 – Left Mounting Channel Assembly

**Refer to Figure 1**

Installer to provide all fasteners.

1. Install Ceiling Collar Assembly to walls through holes provided in top and bottom mounting tabs.
2. Attach Right Mounting Channel and Left Mounting Channel to walls as shown. Attach to wall through holes provided.
3. Attach Cover Mounting Channel to Ceiling Collar Assembly as shown. Use slots in Cover Mounting Channel to locate and drill holes. Fasten Cover Mounting Channel to Ceiling Collar Assembly.
4. Hook Removable Cover Assembly in place as shown.

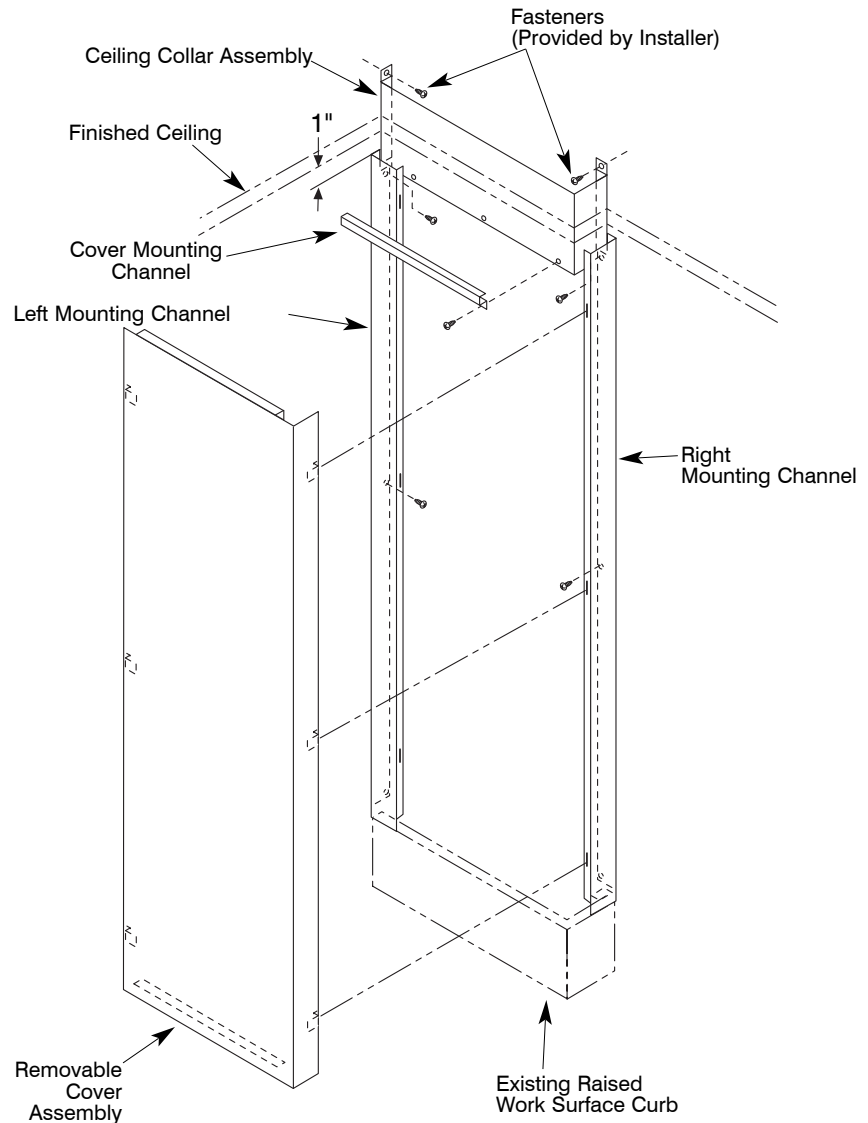

**Figure 1**

*Umbilical rests on pedestal curb  
– part of work surface*

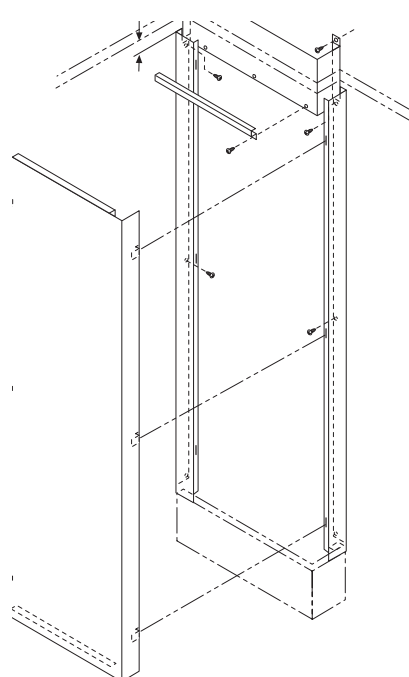

**Tools Required:**

Power Drill  
Phillips Head Screwdriver

**Hardware Included:**

- 1 – Ceiling Collar Assembly
- 1 – Cover Mounting Channel
- 1 – Removable Cover Assembly
- 1 – Right Mounting Channel Assembly
- 1 – Left Mounting Channel Assembly

**Refer to Figure 1**

Installer to provide all fasteners.

1. Install Ceiling Collar Assembly to walls through holes provided in top and bottom mounting tabs.
2. Attach Right Mounting Channel and Left Mounting Channel to walls as shown. Attach to wall through holes provided.
3. Attach Cover Mounting Channel to Ceiling Collar Assembly as shown. Use slots in Cover Mounting Channel to locate and drill holes. Fasten Cover Mounting Channel to Ceiling Collar Assembly.
4. Hook Removable Cover Assembly in place as shown.

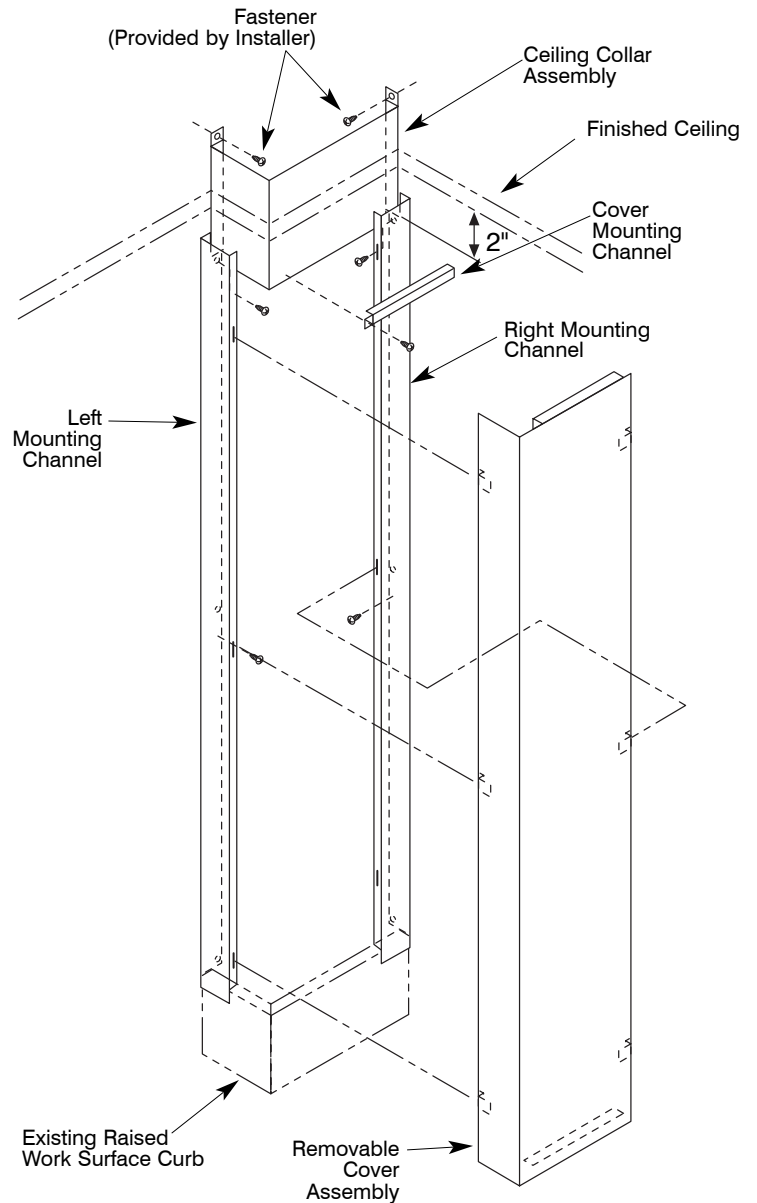
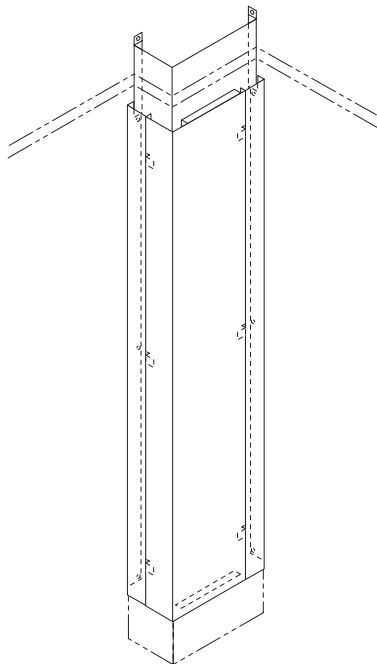

**Figure 1**

*Umbilical rests on pedestal curb  
– part of work surface*

**Tools Required:**

- Power Drill
- Phillips Head Screwdriver

**Hardware Included:**

- 1 – Ceiling Collar Assembly
- 1 – Cover Mounting Channel
- 1 – Removable Cover Assembly
- 1 – Right Mounting Channel Assembly
- 1 – Left Mounting Channel Assembly

**Refer to Figure 1**

Installer to provide all fasteners.

1. Install Ceiling Collar Assembly to walls through holes provided in top and bottom mounting tabs.
2. Attach Right Mounting Channel and Left Mounting Channel to walls as shown. Attach to wall through holes provided.
3. Attach Cover Mounting Channel to Ceiling Collar Assembly as shown. Use slots in Cover Mounting Channel to locate and drill holes. Fasten Cover Mounting Channel to Ceiling Collar Assembly.
4. Hook Removable Cover Assembly in place as shown.

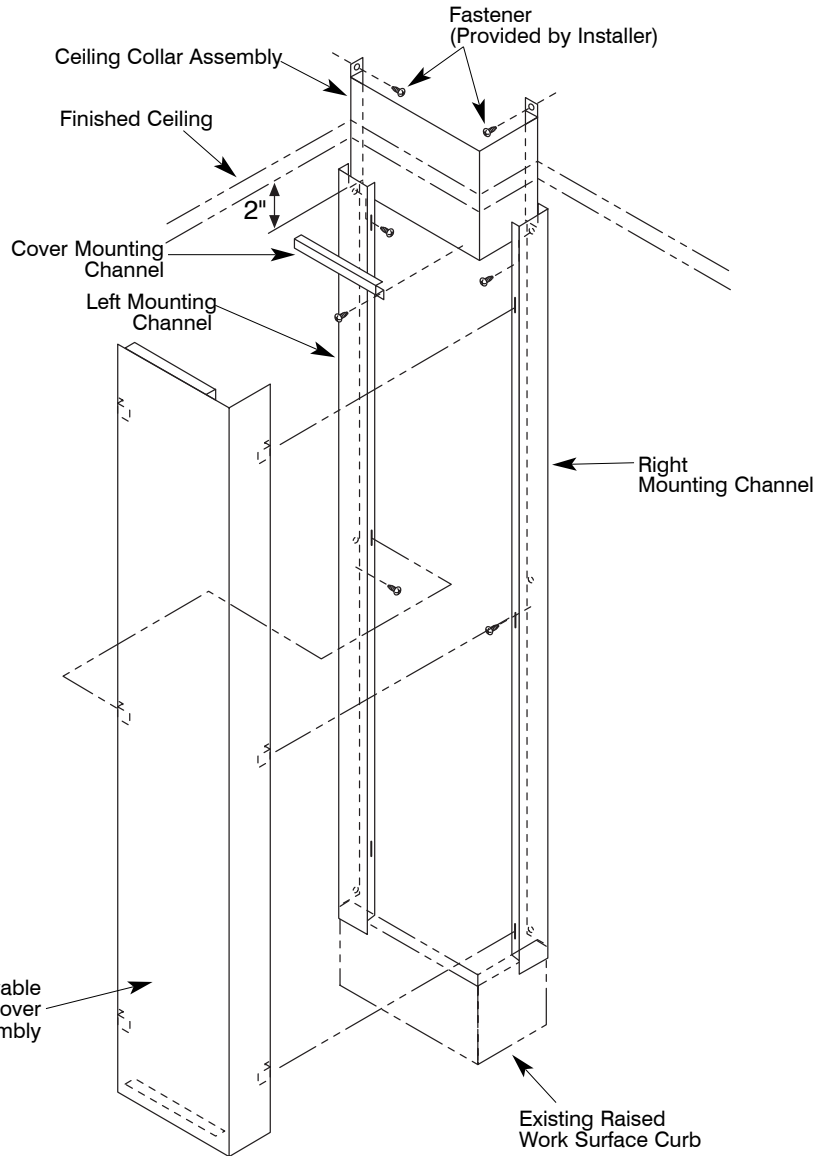

**Figure 1**

*Umbilical rests on pedestal curb – part of work surface*

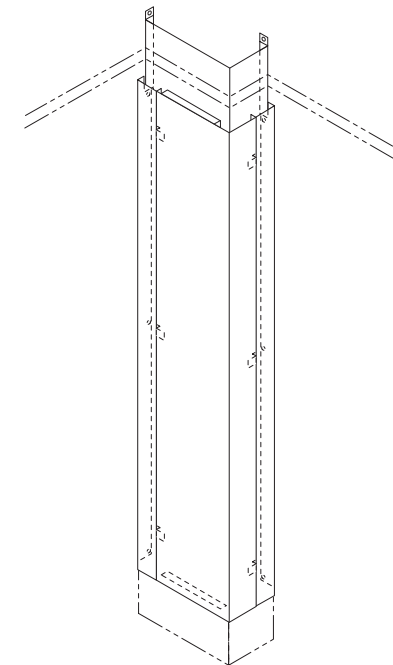

**Tools Required:**

Power Drill  
Phillips Head Screwdriver  
Pop Rivet Gun

**Hardware Included:**

- 1 – Ceiling Collar Assembly, 2-halves
- 2 – Cover Mounting Channels
- 1 – Removable Cover Assembly
- 1 – Fixed Body Assembly

**Refer to Figure 1**

Installer to provide all fasteners.

1. Pop rivet Ceiling Collar halves together.
2. Attach Cover Mounting Channel to the two long sides of the Ceiling Collar Assembly. Use slots in Cover Mounting Channel to locate and drill holes. Fasten Cover Mounting Channel to Ceiling Collar Assembly.
3. Hook Fixed Body Assembly in place over Cover Mounting Channel.
4. Hook Removable Cover Assembly in place over Cover Mounting Channel as shown.

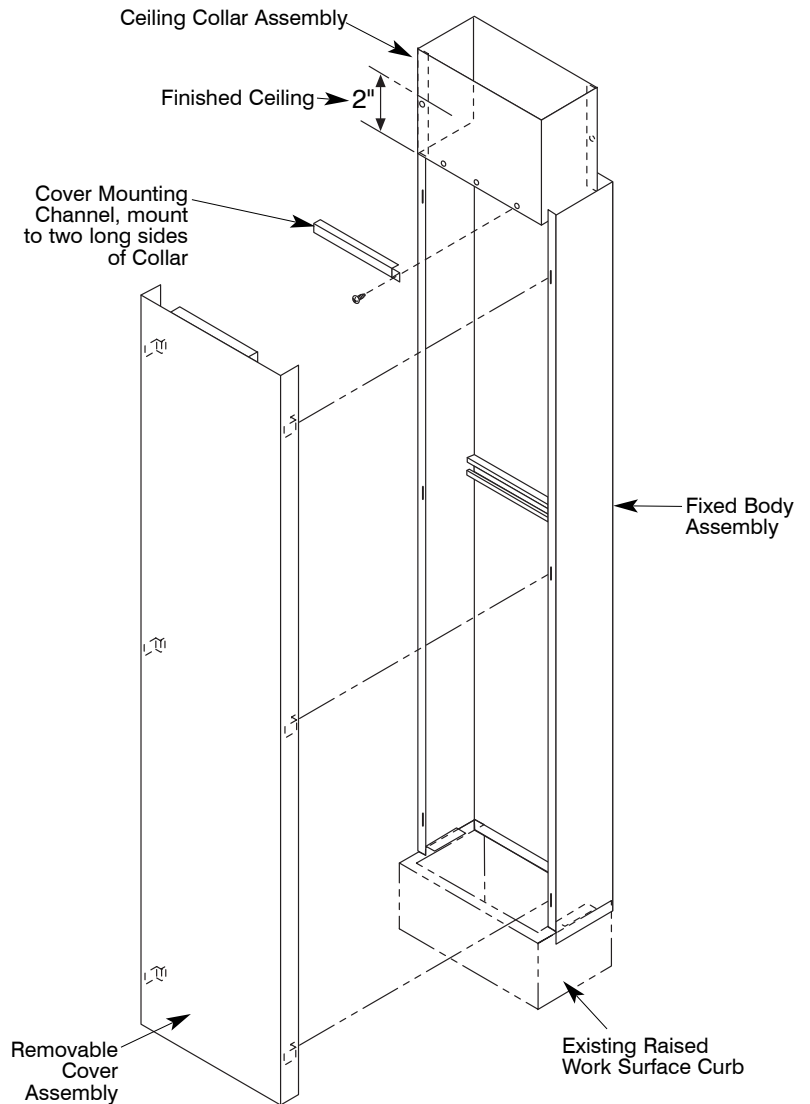
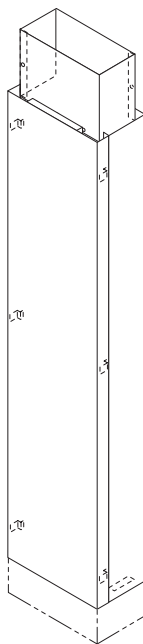

**Figure 1**

*Umbilical rests on pedestal curb  
– part of work surface*

**Tools Required:**

Power Drill  
Phillips Head Screwdriver

**Hardware Included:**

- 1 – Ceiling Collar Assembly
- 1 – Cover Mounting Channel
- 1 – Removable Cover Assembly
- 1 – Right Mounting Channel Assembly
- 1 – Left Mounting Channel Assembly

**Refer to Figure 1**

Installer to provide all fasteners.

1. Install Ceiling Collar Assembly to wall through holes provided in top and bottom mounting tabs.
2. Attach Right Mounting Channel and Left Mounting Channel to walls as shown. Attach to wall through holes provided.
3. Attach Cover Mounting Channel to Ceiling Collar Assembly as shown. Use slots in Cover Mounting Channel to locate and drill holes. Fasten Cover Mounting Channel to Ceiling Collar Assembly.
4. Hook Removable Cover Assembly in place as shown.

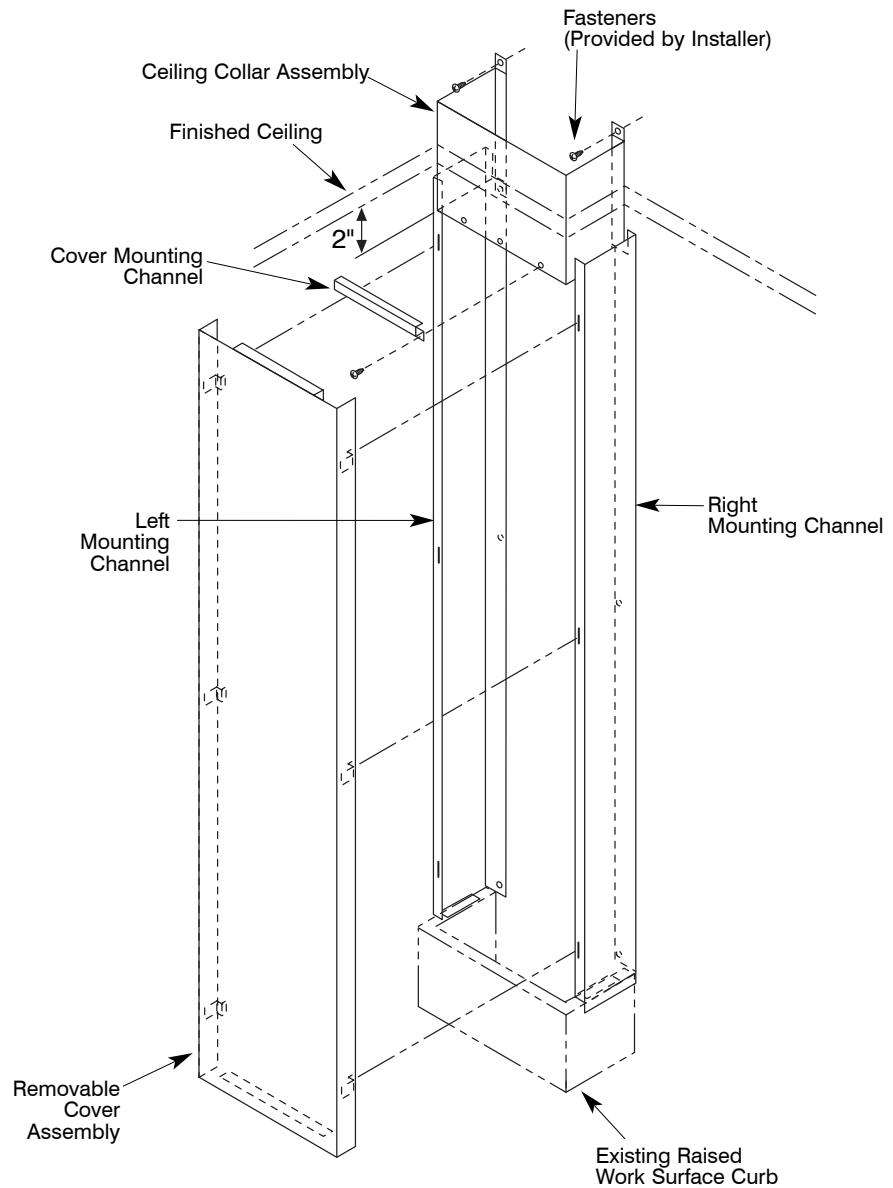

**Figure 1**

*Umbilical rests on pedestal curb  
– part of work surface*